

**144/430MHz DUAL BAND
FM TRANSCEIVER**

IC-3200A/E

SERVICE MANUAL



ICOM INCORPORATED

1-6-19, Kamikuratsukuri, Hirano-ku, Osaka 547, Japan
Phone: (06) 793-5301
Telex: ICOM TR J63649

ICOM AMERICA, INC.

2380 116th Avenue N.E.
Bellevue, Washington 98004
Phone: (206) 454-8155
Telex: 230-152210 ICOM AMER BVUE
FAX : (206) 454-1509

3331 Towerwood Drive
Suite 307
Dallas, Texas 75234
Phone: (214) 620-2781
Telex: 230-730901 ICOM AMER DAL

1777 Phoenix Parkway
Suite 201
Atlanta, Georgia 30349
Phone: (404) 991-6166

ICOM EUROPE G.M.B.H

Himmelgeister Strasse 100
4000 Dusseldorf 1
West Germany
Phone: 0211-346047
Telex: 41-8588082 ICOM D
Fax : 211-333639

ICOM CANADA LTD.

3071-#5 Road, Unit 9
Richmond, B.C.
Canada V6X 2T4
Phone: (604) 273-7400
Fax : (604) 325-0828

ICOM AUSTRALIA, PTY., LTD.

7 Duke Street, Windsor 3181
Victoria, Australia
Phone: (03) 529-7582
Telex: 71-35521 ICOMAS

FOREWORD

Thank you for selecting ICOM's versatile **IC-3200A/E**, one of the finest FM mobile transceivers on the market today.

Sophisticated in design, yet light, compact, and easy to operate, the **IC-3200A/E** benefits from the latest in ICOM engineering techniques and from ICOM's established leadership in the communications field.



The picture shows the IC-3200E version.

ASSISTANCE

Three separate versions of the **IC-3200A/E** have been designed for use in the U.S.A., Europe, and Australia. This service manual covers every version. When using the manual each model can be referred to by the following assigned version numbers:

- #03 U.S.A. version
- #04 EUROPE version
- #05 (VK) AUSTRALIA version

If you require assistance or information regarding the operation and capabilities of the **IC-3200A/E**, please contact your nearest authorized ICOM Dealer or ICOM Service Center.

TABLE OF CONTENTS

SECTION 1	SPECIFICATIONS	1 - 1
1-1	GENERAL	1 - 1
1-2	TRANSMITTER	1 - 1
1-3	RECEIVER	1 - 1
SECTION 2	OPERATING CONTROLS AND INDICATORS	2 - 1 ~ 2
2-1	FRONT PANEL	2 - 1
2-2	DISPLAY	2 - 2
2-3	REAR PANEL	2 - 2
SECTION 3	CIRCUIT DESCRIPTION	3 - 1 ~ 6
3-1	RECEIVER CIRCUITS	3 - 1
3-2	TRANSMITTER CIRCUITS	3 - 1
3-3	PLL (PHASE-LOCKED LOOP) CIRCUITS	3 - 3
3-4	LOGIC CIRCUITS	3 - 4
SECTION 4	VOLTAGE/CIRCUIT DIAGRAMS	4 - 1 ~ 9
4-1	WIRING DIAGRAM	4 - 1
4-2	EF (VOL AND SQL) UNITS	4 - 2
4-3	MAIN (UHF) UNIT	4 - 3
4-4	MAIN (VHF) UNIT	4 - 4
4-5	PLL-YGR (UHF) UNIT	4 - 5
4-6	PLL-YGR (VHF) UNIT	4 - 6
4-7	LOGIC A UNIT	4 - 7
4-8	LOGIC B UNIT	4 - 8
4-9	PA (UHF, VHF) UNITS	4 - 9
SECTION 5	MAINTENANCE AND ADJUSTMENT	5 - 1 ~ 7
5-1	PREPARATION BEFORE SERVICING	5 - 1
5-2	PLL ADJUSTMENT	5 - 2
5-3	RECEIVER ADJUSTMENT	5 - 3
5-4	TRANSMITTER (UHF BAND) ADJUSTMENT	5 - 4
5-5	TRANSMITTER (VHF BAND) ADJUSTMENT	5 - 6
SECTION 6	TROUBLESHOOTING	6 - 1 ~ 2
SECTION 7	INSIDE VIEWS	7 - 1 ~ 4
7-1	MAIN UNIT	7 - 1
7-2	PLL-YGR UNIT (IC-3200A/VK VERSIONS)	7 - 2
7-3	PLL-YGR UNIT (IC-3200E VERSION)	7 - 3
7-4	LOGIC UNITS	7 - 4
SECTION 8	DISASSEMBLY AND ASSEMBLY DIAGRAMS	8 - 1 ~ 4
8-1	FRAME DISASSEMBLY	8 - 1
8-2	FRONT PANEL DISASSEMBLY	8 - 2
8-3	MAIN UNIT CONNECTOR ASSEMBLY	8 - 3
8-4	PLL-YGR CONNECTOR ASSEMBLY	8 - 4

SECTION 9	BOARD LAYOUTS	9 — 1 ~ 6
9-1	MAIN UNIT	9 — 1
9-2	PLL-YGR UNIT	9 — 2
9-3	LOGIC A UNIT	9 — 3
9-4	LOGIC B UNIT	9 — 3
9-5	PA (VHF) UNIT	9 — 4
9-6	PA (UHF) UNIT	9 — 4
9-7	TX VCO UNIT	9 — 5
9-8	RX VCO UNIT	9 — 5
9-9	EF (VOL) UNIT	9 — 6
9-10	EF (SQL) UNIT	9 — 6
SECTION 10	BLOCK DIAGRAM	10 — 1
SECTION 11	IC RATINGS	11 — 1 ~ 11
SECTION 12	OPTIONAL UNITS	12 — 1 ~ 2
SECTION 13	PARTS LIST	13 — 1 ~ 10
	EF (VOL AND SQL) UNITS	13 — 1
	MAIN UNIT	13 — 1
	RX VCO UNIT	13 — 3
	TX VCO UNIT	13 — 4
	PLL-YGR UNIT	13 — 4
	LOGIC A UNIT	13 — 7
	LOGIC B UNIT	13 — 8
	PA (UHF AND VHF) UNITS	13 — 9
SECTION 14	SCHEMATIC DIAGRAM	SEPARATE

SECTION 1 SPECIFICATIONS

1 - 1 GENERAL

Number of semiconductors	:	Transistors	49																							
		FETs	10																							
		Diodes	85																							
Frequency coverage and Channel resolution	:	<table border="1"> <thead> <tr> <th>VERSION</th> <th>BAND</th> <th>FREQUENCY COVERAGE (MHz)</th> <th>CHANNEL RESOLUTION (kHz)</th> </tr> </thead> <tbody> <tr> <td rowspan="2">IC-3200A U.S.A.</td> <td>VHF</td> <td>140.0 ~ 150.0</td> <td>15 or 5</td> </tr> <tr> <td>UHF</td> <td>440.0 ~ 450.0</td> <td>25 or 5</td> </tr> <tr> <td rowspan="2">IC-3200E EUROPE</td> <td>VHF</td> <td>144.0 ~ 146.0</td> <td rowspan="2">25 or 12.5</td> </tr> <tr> <td>UHF</td> <td>430.0 ~ 440.0</td> </tr> <tr> <td rowspan="2">IC-3200A VK</td> <td>VHF</td> <td>144.0 ~ 148.0</td> <td rowspan="2">25 or 5</td> </tr> <tr> <td>UHF</td> <td>430.0 ~ 440.0</td> </tr> </tbody> </table>		VERSION	BAND	FREQUENCY COVERAGE (MHz)	CHANNEL RESOLUTION (kHz)	IC-3200A U.S.A.	VHF	140.0 ~ 150.0	15 or 5	UHF	440.0 ~ 450.0	25 or 5	IC-3200E EUROPE	VHF	144.0 ~ 146.0	25 or 12.5	UHF	430.0 ~ 440.0	IC-3200A VK	VHF	144.0 ~ 148.0	25 or 5	UHF	430.0 ~ 440.0
VERSION	BAND	FREQUENCY COVERAGE (MHz)	CHANNEL RESOLUTION (kHz)																							
IC-3200A U.S.A.	VHF	140.0 ~ 150.0	15 or 5																							
	UHF	440.0 ~ 450.0	25 or 5																							
IC-3200E EUROPE	VHF	144.0 ~ 146.0	25 or 12.5																							
	UHF	430.0 ~ 440.0																								
IC-3200A VK	VHF	144.0 ~ 148.0	25 or 5																							
	UHF	430.0 ~ 440.0																								
Usable temperature range	:	-10°C +60°C (+14°F~140°F)																								
Frequency control	:	Micro computer-based 5kHz steps (or 12.5kHz steps) Digital PLL synthesizer with independent dual VFO capability																								
Frequency stability	:	Within ±0.001%																								
Power supply requirement	:	13.8V DC ±15% (negative ground) 7.5A maximum																								
Current drain (13.8V DC)	:	Transmitting HIGH (25W) : Approx. 7.5A LOW (5W) : Approx. 3.5A Receiving At max. audio output : Approx. 0.65A Squelched : Approx. 0.5A																								
Memory channels	:	10 channels with any in-band frequency programmable																								
Antenna impedance	:	50Ω unbalanced																								
Weight	:	1.9kg																								
Dimensions	:	140(140)mm(W) x 50(50)mm(H) x 207(218)mm(D) Bracketed values include projections																								

1 - 2 TRANSMITTER

Output power	:	HIGH: 25W, LOW: 5W
Emission mode	:	16F3 (F3E 16K0)
Modulation system	:	Variable reactance frequency modulation
Max. frequency deviation	:	±5kHz
Spurious emissions	:	More than 60dB below carrier
Microphone	:	600 Ω electret condenser microphone with Push-To-Talk and frequency UP/DOWN SWITCHES IC-3200A (U.S.A. version only): 16 key DTMF pad IC-3200E: 1750Hz Tone Burst unit
Operating modes	:	Simplex, Semi-duplex, Programmable

1 - 3 RECEIVER

Receiving system	:	Double-conversion superheterodyne
Modulation acceptance	:	16F3 (F3E 16KO)
Intermediate frequencies	:	1st: 30.875MHz 2nd: 455kHz
Selectivity	:	More than 15kHz at -6dB point Less than 30kHz at -60dB point
Sensitivity	:	Less than 0.2μV for 12dB SINAD Less than 0.4μV for 20dB noise quieting
Audio output power	:	More than 1.7W at 10% distortion with 8Ω load
Audio output impedance	:	4~8Ω

NOTE: Specifications are approximate and are subject to change without notice or obligation.

SECTION 2 OPERATING CONTROLS AND INDICATORS

2-1 FRONT PANEL

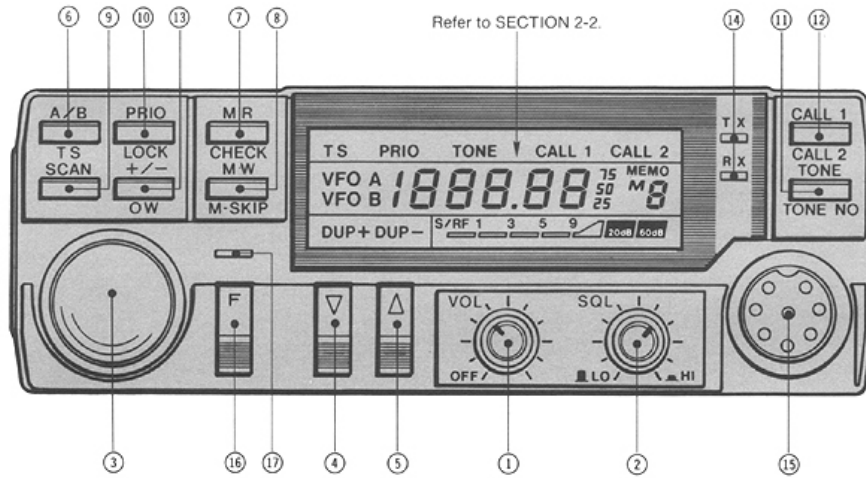

- ① VOLUME AND POWER CONTROL
- ② SQUELCH AND RF POWER CONTROL
- ③ TUNING CONTROL
- ④ MHz DOWN SWITCH
- ⑤ MHz UP SWITCH
- ⑥ A/B AND TUNING SPEED SWITCH
- ⑦ MEMORY READ AND OFFSET CHECK SWITCH
- ⑧ MEMORY WRITE AND MEMORY SKIP SWITCH
- ⑨ SCAN AND SELECTIVE MEMORY SCAN SWITCH
- ⑩ PRIORITY AND LOCK SWITCH
- ⑪ CALL 1 AND CALL 2 SWITCH
- ⑫ TONE SWITCH AND OFFSET WRITE SWITCH
- ⑬ OFFSET AND OFFSET WRITE SWITCH
- ⑭ TRANSMIT AND RECEIVE INDICATORS
- ⑮ MIC CONNECTOR
- ⑯ FUNCTION SWITCH
- ⑰ FUNCTION LED INDICATOR

2 - 2 DISPLAY

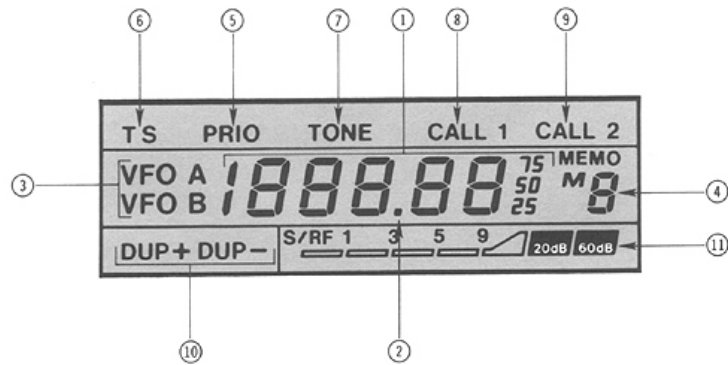

- ① FREQUENCY DISPLAY
- ② FUNCTION INDICATOR
- ③ VFO INDICATORS
- ④ MEMORY CHANNEL INDICATOR
- ⑤ PRIO INDICATOR
- ⑥ TS INDICATOR
- ⑦ TONE INDICATOR
- ⑧ CALL 1 INDICATOR
- ⑨ CALL 2 INDICATOR
- ⑩ DUPLEX INDICATORS (+/-)
- ⑪ S/RF LEVEL METER

2 - 3 REAR PANEL

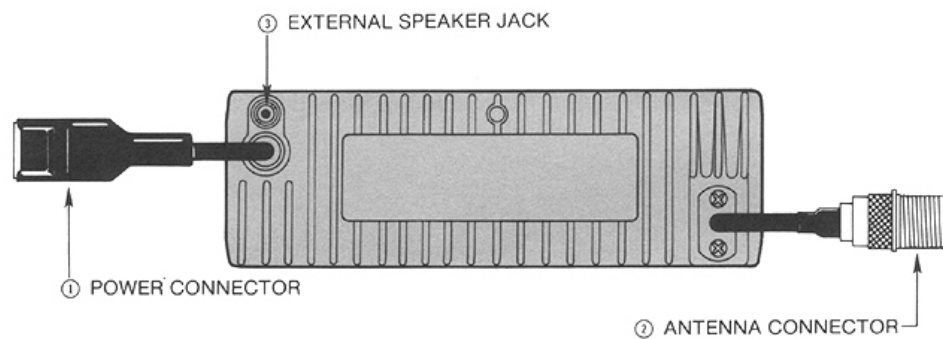

- ① POWER CONNECTOR
- ② ANTENNA CONNECTOR
- ③ EXTERNAL SPEAKER JACK

SECTION 3 CIRCUIT DESCRIPTION

3 - 1 RECEIVER CIRCUITS

3 - 1 - 1 VHF ANTENNA SWITCHING CIRCUIT (PA UNIT)

Incoming VHF signals from the antenna connector are passed through a Chebyshev Low-pass filter consisting of L3, L4, L6, C12, C13, C14, and C15, and are fed to the antenna switching circuit. While receiving, D2 is turned ON. Receive signals from a low-pass filter are passed through another filter consisting of C10, L2 and C17, and are fed to J1 on the MAIN UNIT.

3 - 1 - 2 VHF RF AMPLIFIER CIRCUIT (MAIN UNIT)

Signals from J1 are passed through the L1-L2 bandpass filter, and are amplified by Q1. Amplified signals from Q1 are passed through the L3-L4-L5 bandpass filter, and are mixed with the local oscillator signal from the PLL circuit in Q2 to produce a first IF signal of 30.875MHz.

3 - 1 - 3 UHF ANTENNA SWITCHING CIRCUIT (PA UNIT)

Incoming VHF signals from the antenna connector are passed through both a Chebyshev low-pass filter consisting of L13, L14, C35, C36 and C37 and a Chebyshev low-pass filter consisting of L11, L13, C32, C33 and C34 before being fed into the antenna switching circuit. While receiving, D5 is turned OFF. Receive signals from the low-pass filter are passed through another filter consisting of L10, C30, C39 and C40, and are fed to J3 on the MAIN UNIT.

3 - 1 - 4 UHF RF AMPLIFIER CIRCUIT (MAIN UNIT)

Signals from J3 are passed through a tuned circuit consisting of L11, C21 and C22, and the output is amplified by Q5. The output from Q5 is passed through bandpass filter L13, amplifier Q6, bandpass filter L15, and is mixed with the local oscillator signal from the PLL UNIT to produce a first IF signal of 30.875MHz.

3 - 1 - 5 IF AMPLIFIER CIRCUIT (MAIN UNIT)

The first IF signal from the mixer is passed through the L8-C12 tuned circuit, is filtered by crystal filter FI1, is passed through the L9-C15 tuned circuit, and is amplified by Q4. D3 and D4 function as a limiter for strong signals. The amplified signal from Q4 is fed to pin 16 of IC1. IC1 incorporates a second oscillator, a second mixer, a limiter and a discriminator on a single chip. The signal from pin 16 of IC1 is mixed with the second oscillator signal to produce the 455kHz signal at pin 3 on IC1. The 455kHz signal is filtered by ceramic filter FI2 and is fed to pin 5 of IC1 where it then enters the limiter amplifier. The amplified signal is fed to the discriminator through ceramic discriminator unit X1. The audio signal exits from pin 9 on IC1.

3 - 1 - 6 AUDIO AMPLIFIER CIRCUIT (MAIN UNIT)

The audio signal from pin 9 on IC1 is amplified by Q10, is

filtered by active filter Q11, and is fed through J7 and the VOLUME CONTROL to pin 1 on IC5. IC5 is the audio power amplifier. The amplified audio signal from IC5 is fed to the speaker through J10.

3 - 1 - 7 SQUELCH CIRCUIT (MAIN UNIT)

The audio signal from pin 9 on IC1 is also fed to the noise amplifier through C69, R50, J8, C70, and the SQUELCH CONTROL and then is input to pin 10 on IC1. The amplified noise signal exits from pin 11 on IC1, is rectified by D11 and D12, and is controlled by Q9 through R54.

3 - 1 - 8 S-METER CIRCUIT (MAIN UNIT)

S-meter signals from pin 5 on IC1 are amplified by IC3 through C66 and R49, are passed through L20, are rectified by D9 and D10, and are fed to the LCD driver circuit on the LOGIC A UNIT through J12. In the VHF mode, the band signal turns ON Q12 to adjust the gain of IC3 by means of R82, equalizing the S-meter level between VHF and UHF.

3 - 2 TRANSMITTER CIRCUITS

3 - 2 - 1 MIC AMPLIFIER CIRCUIT (PLL UNIT)

The microphone output is fed into IC5A through C60 and the Q8 amplifier. IC5A includes a differential amplifier and a limiter amplifier with R2 as the UHF deviation gain adjustment and R3 as the VHF deviation gain adjustment. Preemphasis of 6dB/octave is introduced between 300Hz and 3kHz. The signal is then fed to the FM modulator in the TX VCO UNIT through a low-pass filter consisting of IC5B, R45, R46, R49, C51, C52, and C53.

3 - 2 - 2 MICROPHONES USED WITH THE IC-3200A/E

The IC-3200A/E comes factory equipped with a high-quality electret condenser microphone. The type of supplied microphone varies with each transceiver model. The microphone types are listed below.

IC-3200A (#03) : IC-HM14 (DTMF Encoder)
IC-3200E (#04) : IC-HM15 (1750Hz Tone Burst)
IC-3200A (#05) : IC-HM12

1. IC-HM14 (DTMF Encoder) MIC

Plug the IC-HM14 into the MIC CONNECTOR on the front panel for immediate transceiver operation. If you wish to use a different microphone with the IC-3200A, be sure it has the proper output level before making any connections. Particular care should be exercised when wiring a different microphone since the internal electrical switching system in the transceiver depends on proper connections being made. See the diagram on page 3-2 for proper MIC wiring instructions.

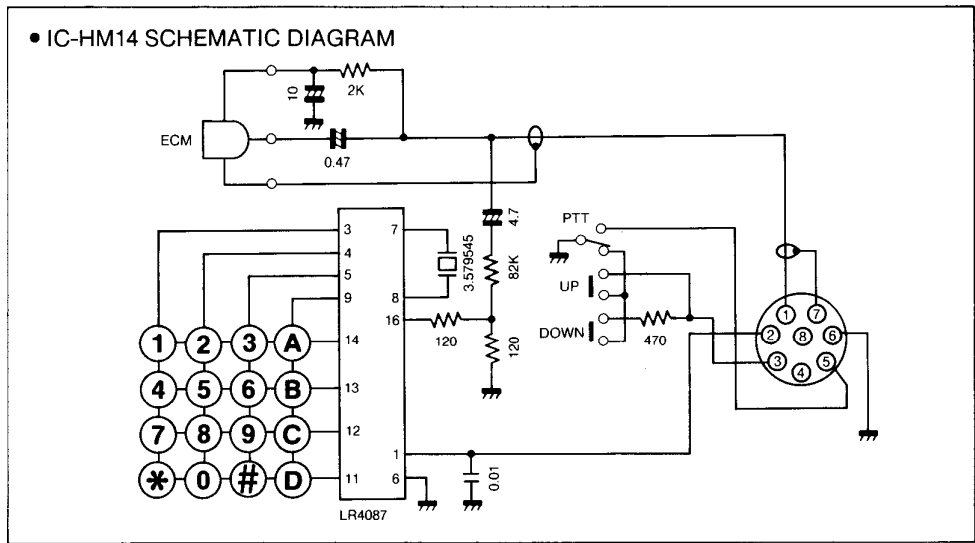

2. IC-HM15 (1750Hz Tone Burst) MIC
 The IC-HM15 is equipped with a 1750Hz tone burst switch for convenient access to repeaters. Refer to the IC-HM15

schematic diagram below for information regarding its internal wiring and components.

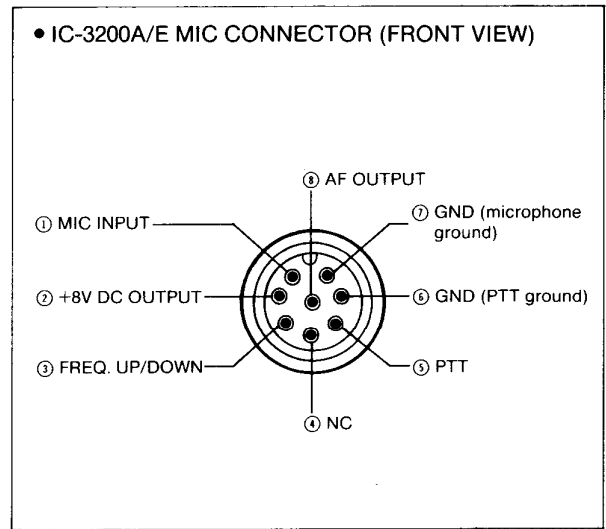
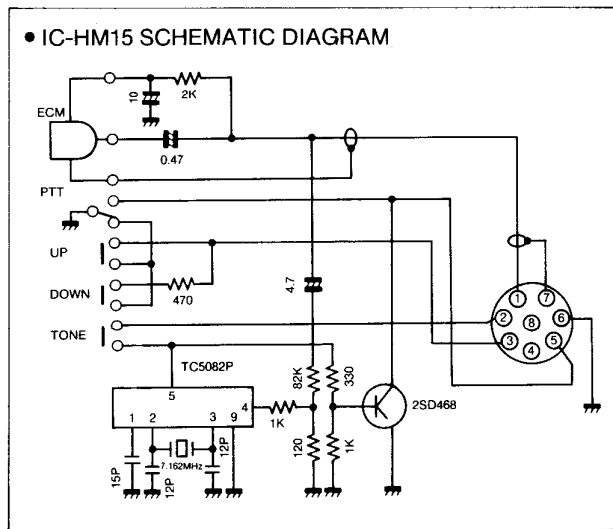

3. IC-HM12 (Electret Condenser) MIC
 Refer to the schematic diagram below for information

regarding the internal wiring and components in the IC-HM12.

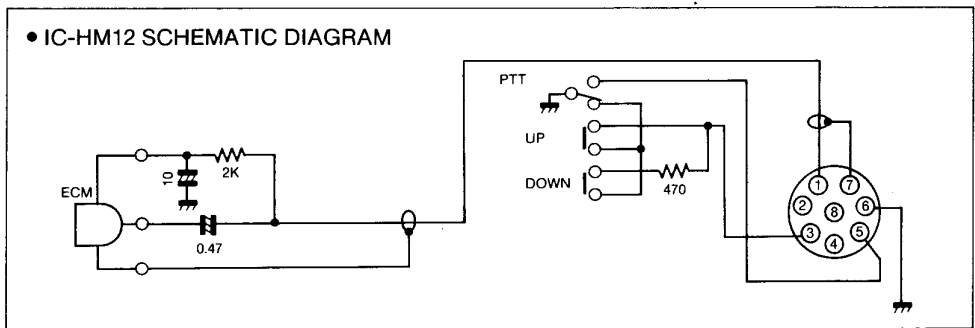

3 - 2 - 3 MULTIPLIER AND DRIVER CIRCUITS

1. VHF Circuit

The RF signal from the PLL UNIT is amplified by IC1 on the VHF PA UNIT to obtain 25W, and the output from pin 4 on IC1 is fed to the ANT switching circuit. In the transmit mode D2 and D4 in the T/R switching circuit are turned ON, and L2 and C2 become a parallel resonant circuit. The output power from pin 4 on IC1 is fed to the antenna terminal through the bandpass filter.

2. UHF Circuit

The RF signal from the PLL UNIT is amplified by IC2 on the UHF PA UNIT to obtain 25W, and the output from pin 5 on IC2 is fed to the ANT switching circuit. In the transmit mode, D5 and D7 in the T/R switching circuit are turned ON, and L15 and C41 become a parallel resonant circuit. The output power from pin 5 on IC2 is fed to the antenna terminal through the bandpass filter.

3. VHF/UHF ALC (Automatic Level Control) Circuit (PA UNITS AND MAIN UNIT)

This circuit stabilizes the output power even when the power supply voltage or the antenna impedance is fluctuating. The varying current from the power amplifier at R1 (VHF) and R6 and R11 (UHF) is amplified by the IC2B (VHF) or IC2A (UHF) differential amplifiers on the MAIN UNIT. The output voltage is fed to Q1 (VHF) or Q3 (UHF) which control the current to the module's driver stage, maintaining constant RF power.

4. VHF/UHF RF Meter Circuit (PA UNITS AND MAIN UNIT)

A sample of the RF output power is fed to D3 (VHF) or D6 (UHF) through C9 (VHF) or C27 (UHF), is rectified, and is passed to the module's driver stage to maintain constant RF power.

5. Power Supply Circuit (MAIN UNIT)

The 13.8V from the DC connector is applied to IC4 on the MAIN UNIT through filters consisting of L22, C97, and R89. This causes 9V to be fed to the MAIN and PLL-YGR UNITS.

3 - 3 PLL (PHASE-LOCKED LOOP) CIRCUITS

3 - 3 - 1 PLL

The PLL is designed so that the desired frequency is generated directly by the VCO using a dual modulation prescaler system, and is composed of the IC2 prescaler IC and the IC1 PLL IC. The PLL circuit is fed "divided-by-N" DATA from the CPU to determine the operating frequency. N-DATA is the ratio of the desired frequency (the transmit frequency in transmit mode and the first local oscillator frequency in receive mode) and the reference frequency.

$$N = \frac{\text{Desired frequency}}{\text{Reference frequency}}$$

Crystal X1 oscillates in Q1 and its output signal is divided by a dividing circuit in IC1 that obtains a reference frequency of 5kHz for the IC-3200A (6.25kHz for the IC-3200E version).

The signal from the VCO that is buffer-amplified at Q6 is divided N times at IC2 and IC1. The signal inside IC1 is phase detected and the detected signal is output from pin 11 on IC1. The output signal is applied to the TX D1 and TX D2 varactor diodes (or RX D1 and RX D2) in the VCO and is passed through the Q2-Q3 loop filter to control the VCO frequency.

3 - 3 - 2 VCO/FM MODULATION CIRCUITS

The VCO is composed of the following circuits: VHF RX, UHF RX, VHF TX, and UHF TX. A PD signal from the PLL is fed to the varactor diode connected to each drain of the FETs to control the VCO frequency.

1. Dual Modulus Prescaler

IC2 is a dual modulus prescaler that divides the signal generated by the VCO by either 64 or 65. The VHF receive range is 102.125~119.125MHz and the transmit range is 140.00~150.00MHz. The UHF receive range is 409.125~419.125MHz and the transmit range is 440.00~450.00MHz. IC1 is a CMOS LSI chip designed for use as a frequency synthesizer. It incorporates a 6-bit swallow counter, an 11-bit programmable counter, a phase comparator, a charge pump, and a frequency divider for the reference frequency. The reference frequency from Q1 is fed to pin 15 on IC1. Here the frequency is divided by 1024, the reference frequency becomes 5kHz (6.25kHz for the IC-3200E version), and the frequency is fed to pin 2 on IC1.

2. VHF/UHF RX VCO Circuit

The RX VCO is a Clapp oscillator circuit which oscillates in the VHF range 107.125~119.125MHz or in the UHF range 409.125~419.125MHz. The frequency is controlled by the DC voltage from VRXC on IC3. The drains of Q1 (VHF) and Q4 (UHF) receive a positive 9V while the transceiver is in the receive mode and Q2 (VHF) or Q4 (UHF) are turned ON. Thus the frequency is generated when the FET source is at ground level.

3. VHF/UHF TX VCO Circuit

The TX VCO is a Clapp oscillator circuit. The frequency is controlled by the DC voltage from V-VCO-C or U-VCO-C from IC3. When the drains of Q6 (VHF) or Q3 (UHF) receive a positive 9V, Q4 (VHF) or Q3 (UHF) turns ON. The VHF oscillator frequency (140~150MHz) is fed out through C17 and the UHF oscillator frequency (440~450MHz) is fed out through the Q2 multiplier amplifier.

4. Low-pass Filter Circuit

The local oscillator signal from the RX VCO (VHF: 102.125~119.125, UHF: 409.125MHz) is divided by 2 by the Q2 multiplier amplifier. The VHF local oscillator signal is fed to J2 on the MAIN UNIT through D13 and a low-pass filter consisting of L12, L13, C99, C100 and C101. The UHF local oscillator signal is fed to J4 on the MAIN UNIT through D12 and a low-pass filter consisting of L10, L11, C94, C95, and C96.

5. Tone Circuit

IC-3200A Version:

The CTCSS tone circuit is composed of IC7 and IC8. When a tone number is selected, data is sent to IC7 from the CPU. IC7 carries out serial/parallel conversion on the data from the CPU and the results are fed to IC8. IC8 divides the X2 frequency (3.579545MHz) by an amount related to the data from the CPU, and the output is fed from pin 1. The CTCSS tone output level is controlled by R42, then the signal is fed to the TX VCO UNIT.

TONE NO.	FREQUENCY (Hz)
1	67.0
2	71.9
3	74.4
4	77.0
5	79.7
6	82.5
7	85.4
8	88.5
9	91.5
10	94.8
11	97.4
12	100.0
13	103.5
14	107.2

TONE NO.	FREQUENCY (Hz)
15	110.9
16	114.8
17	118.8
18	123.0
19	127.3
20	131.8
21	136.5
22	141.3
23	146.2
24	151.4
25	156.7
26	162.2
27	167.9
28	173.8

TONE NO.	FREQUENCY (Hz)
29	179.9
30	186.2
31	192.8
32	203.5
33	210.7
34	218.1
35	225.1
36	233.6
37	241.8
38	250.3

IC-3200E Version:

The 1750Hz tone-burst circuit is composed of IC8, Q23, and Q24. IC8 is preset for 1750Hz and outputs the tone signal from pin 1. When the [TONE] SWITCH on either the microphone or front panel of the IC-3200E is pushed, IC8 generates a tone and Q24 simultaneously makes a SEND line to ground level, putting the transceiver in transmit mode. The 1750Hz tone output level is controlled by R42 and the signal is then fed to the TX VCO UNIT.

6. Voltage Regulator Circuit (PLL-YGR UNIT)

The supply voltage for the PLL-YGR UNIT includes 10 different values: 13.8V, common 9V, 6V, VR8V, UR8V, VT8V, UT8V, +8V, UT13.8V, and T8V. These voltages are supplied to each unit. A common 9V from IC4 on the MAIN UNIT is supplied to the PLL-YGR UNIT. This 9V is connected to the emitters of Q14 (VT8V), Q13 (UT8V), Q10 (VR8V), and Q9 (VR8V). 13.8V is connected to the emitters of Q11 (VT13.8V) and Q12 (VT13.8V). Q9, Q10, Q11, Q12, Q13, and Q14 are PNP transistors which turn ON when their bases are grounded. The voltage is fed out from the collectors of each transistor. The bases of Q9~Q14 are controlled by IC4 and IC3. IC4 has seven inverter transistors so that when a HIGH level is applied to IC4 from IC3, the output voltage is LOW. IC3 is composed of two decoders and a demultiplexer.

IC3 produces a 4-bit binary output with two inputs (A and B). This input is controlled by three signals: SEND (RX: HIGH, TX: LOW), TX (RX: LOW, TX: HIGH) and BAND A/B (VHF: LOW, UHF: HIGH). When the PLL is out of lock, the ENABLE TERMINAL of IC3 is HIGH, and all output terminals are LOW.

3 - 4 LOGIC CIRCUITS

3 - 4 - 1 CPU

The CPU on the LOGIC B UNIT is a 4-bit CMOS CPU with an LCD driver. The initialization matrix on the LOGIC B UNIT selects the version of the transceiver, and the main matrix on the LOGIC A and LOGIC B UNITS controls the functions of the transceiver.

The CPU controls the PLL, CTCSS and speech synthesizer circuit by means of serial data through IC4D and IC4E on the LOGIC B UNIT.

1. Memory Backup for CPU

A lithium battery (BT1 on the LOGIC B UNIT) is for memory backup when the transceiver is turned OFF. The memory backup mode begins when a pulse is applied to the INTO port on the CPU, stopping the CPU and saving memory data.

3 - 4 - 2 LOGIC A UNIT

1. Stop Circuit

The stop circuit consists of IC3B, IC4B, IC5B, Q7, Q8, and D10. IC3B, Q7, and Q8 function as a NOR gate. D5 and R29 function as an OR gate. IC5B is a Schmitt trigger circuit that uses the junction voltage of D1 as a reference voltage. Therefore, if the 5V line on the LOGIC A UNIT is more than 4V, IC5B feeds out a HIGH level and the one shot circuit consisting of IC4C, C5, and R28 feeds a pulse to the INTO port on the CPU to cancel the CPU mode.

The cathode of D11 is connected to the LCD mute port on the CPU. When the CPU is in the stop mode, the mute port is HIGH but when the stop mode is cancelled, the mute port is LOW. Also, the output level from the IC3, Q7, and Q8 NOR gate is LOW. IC4B is a buffer amplifier which drives Q7. If the supplied voltage to IC5 on the LOGIC A UNIT drops below 3.8V, the output level from IC5 will be LOW and the output level from IC3B will be HIGH. Therefore, the CPU will activate the stop mode. When the CPU is in the stop mode, the LCD mute port on the CPU is HIGH, and the output from IC3B is LOW.

2. TX/RX Switching Circuit

When the PTT SWITCH on the microphone is pushed, pin 5 of J1 becomes LOW and the collector of Q4 becomes HIGH. Q3 reverses this signal to supply the transmit mode signal to the SEND port on the CPU.

3. TX Control

Pin 13 on IC3A is connected to the MUTE port on the CPU to eliminate unwanted signals from being transmitted. If an out-of-band frequency is selected, the output level from IC3A stays LOW to mute the transmit signal when the PTT SWITCH on the microphone is pressed.

4. Power ON Reset Circuit

When the transceiver is turned ON, a signal from IC4C is supplied to IC3C and the main matrix on the LOGIC A UNIT. If the FUNCTION SWITCH is pressed when the transceiver is being switched ON, IC3 sends a reset signal to the CPU.

5. Scan Stop Circuit

When the SQL S signal from the MAIN UNIT is HIGH, it turns ON Q6 and passes the signal to the SCAN STOP port on the CPU. Also, Q6 controls the D13 receive LED.

6. Mic UP/DOWN Circuit

When the UP/DOWN SWITCH on the microphone is pressed, a signal is supplied to the MIC CK port on the CPU. When the UP SWITCH is pushed, the collector of IC5 becomes HIGH. When the DOWN SWITCH is pushed, the collector of IC5 becomes LOW. The CPU receives this signal from the U/D port on the CPU to control the microphone scanning function.

3 - 4 - 3 LOGIC B UNIT

1. Initial Matrix Circuits

IC1, the BCD-To-Decimal Decoder on the LOGIC B UNIT, decodes the initial matrix signal generated by the following diodes on each IC-3200 version:

(1) Q0 → Ax (BAND A/VHF)

This matrix sets the frequency bandwidth on the VHF (BAND A).

NOTE: The value of x will vary with each transceiver version.

(2) Q1 → Ax (BAND B/UHF)

This matrix sets the frequency bandwidth on the UHF (BAND B).

(3) Q4 → A1 (Ax) (REFERENCE A)

This matrix sets the frequency step and reference frequency of the PLL circuit on BAND A. When the matrix (especially Q4 → A1) is ON, a reference frequency of 6.25kHz is selected; when Q4 → A1 is OFF, a reference frequency of 5kHz is selected.

Q4 → Ax

This matrix sets the frequency step on BAND A.

(4) Q5 → A1 (Ax)

This matrix sets the frequency step and the reference frequency of the PLL circuit on BAND B. When the matrix (especially Q5 → A1) is ON, a reference frequency of 6.25kHz is selected; when Q5 A1 is OFF, a reference frequency of 5kHz is selected.

Q5 → Ax (REFERENCE B)

This matrix sets the frequency step on BAND B.

(5) Q6 → A2 (OW A)

This matrix sets the offset frequency in duplex mode on BAND A when transceiver power is turned ON. When the matrix Q6 A1 is ON, an offset frequency of 600kHz is selected.

(6) Q7 → A1(A4) (OW B)

This matrix sets the offset frequency in duplex mode on BAND B when transceiver power is turned ON. When the matrix Q7 A4 is ON, an offset frequency of 5.0MHz is selected. When both Q7 A1 and Q7 A4 are ON, an offset frequency of 7.6MHz is selected for the IC-3200E version.

(7) Q9 → A1 (VOICE SYNTHESIZER ON/OFF)

This matrix sets the ON or OFF condition for the signals of the voice synthesizer unit. When the matrix is OFF, no data signals for the voice synthesizer are output. When the matrix is ON, the data signals are output.

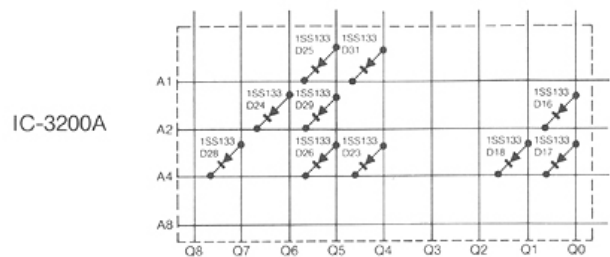

2. Matrix Switch

The matrix data from the LOGIC B UNIT are fed to B1, B2, and B4 on the CPU through S1 to activate the scan speed, the scan timer, and the memory lock functions.

3. Busy Matrix for the Speech Synthesizer

When the speech synthesizer is activated, it sends a busy signal to D3, and turns ON D1 B2 on the main matrix by means of Q1. This alerts the CPU that the synthesizer is activated. The CPU waits until the busy signal is LOW before continuing.

4. BEEP Circuit

The BEEP circuit is a phase oscillator consisting of IC3D, R5, R6, R7, C9, C10, and C11 which feeds out a signal to Q13 on the MAIN UNIT when the control gate is HIGH.

5. DIAL Clock Circuit

This circuit consists of IC2, IC3, Q2, R9, R10, R11, C6 and C7, which form the rotary encoder. When turning the encoder dial, one shot pulses are generated from IC2A. Meanwhile, Q2 generates a HIGH or LOW signal to the U/D port on the CPU for UP or DOWN tuning. Also, IC2A sends sensor signals to the CK port on the CPU.

SECTION 4 VOLTAGE/CIRCUIT DIAGRAMS

4-1 WIRING DIAGRAM

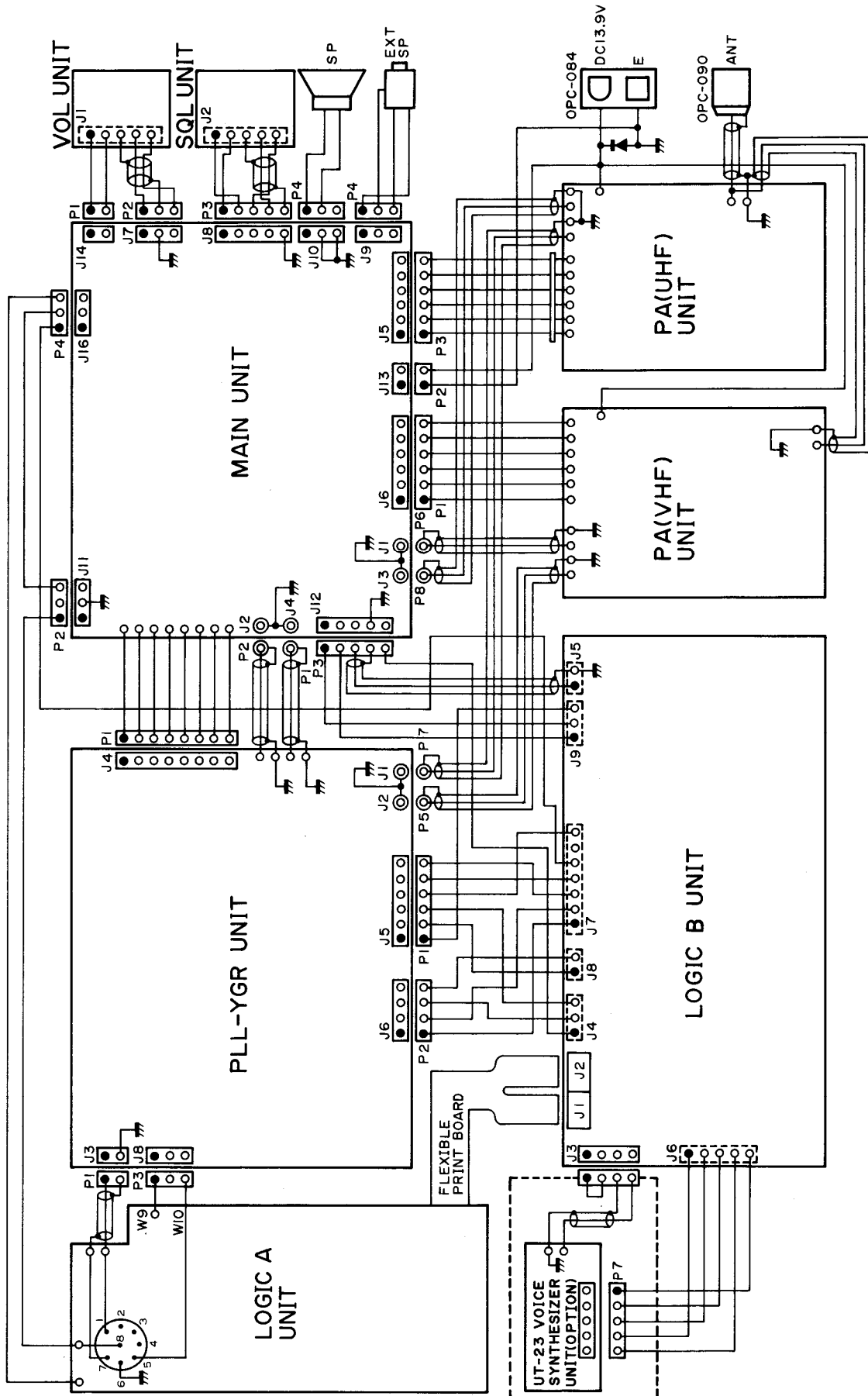

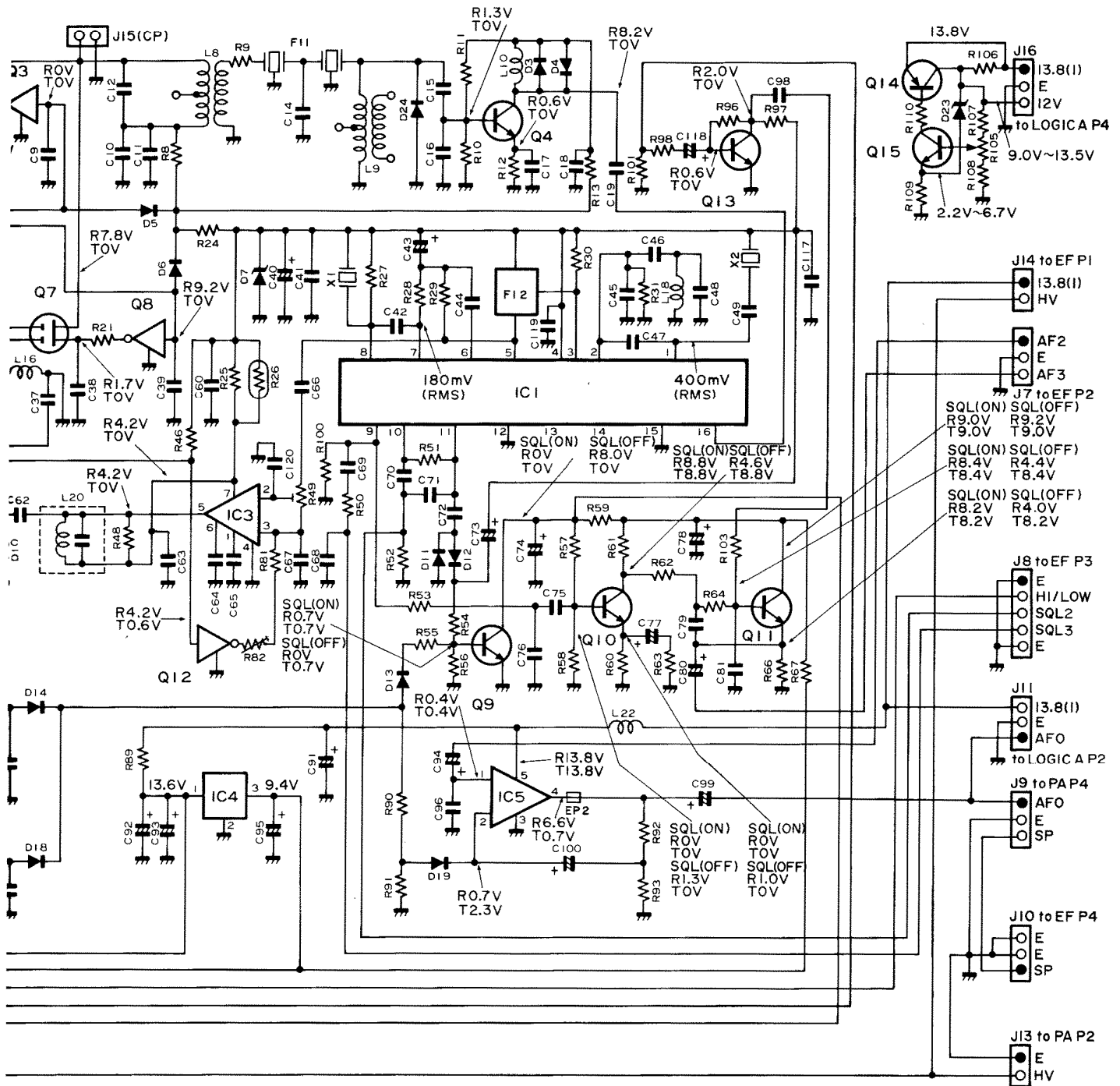

4 - 2 EF (VOL AND SQL) UNITS

(VOL UNIT)

to MAIN J14
13.8(1)
HV

AF2
E
AF3
to MAIN J7

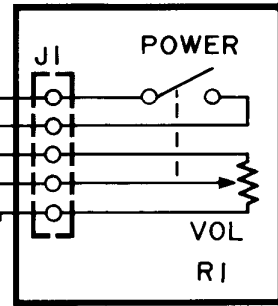

(SQL UNIT)

to MAIN J8
E
HI/LOW
SQL2
SQL3
E

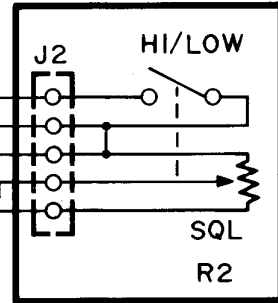
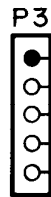

to MAIN J10
SP
E



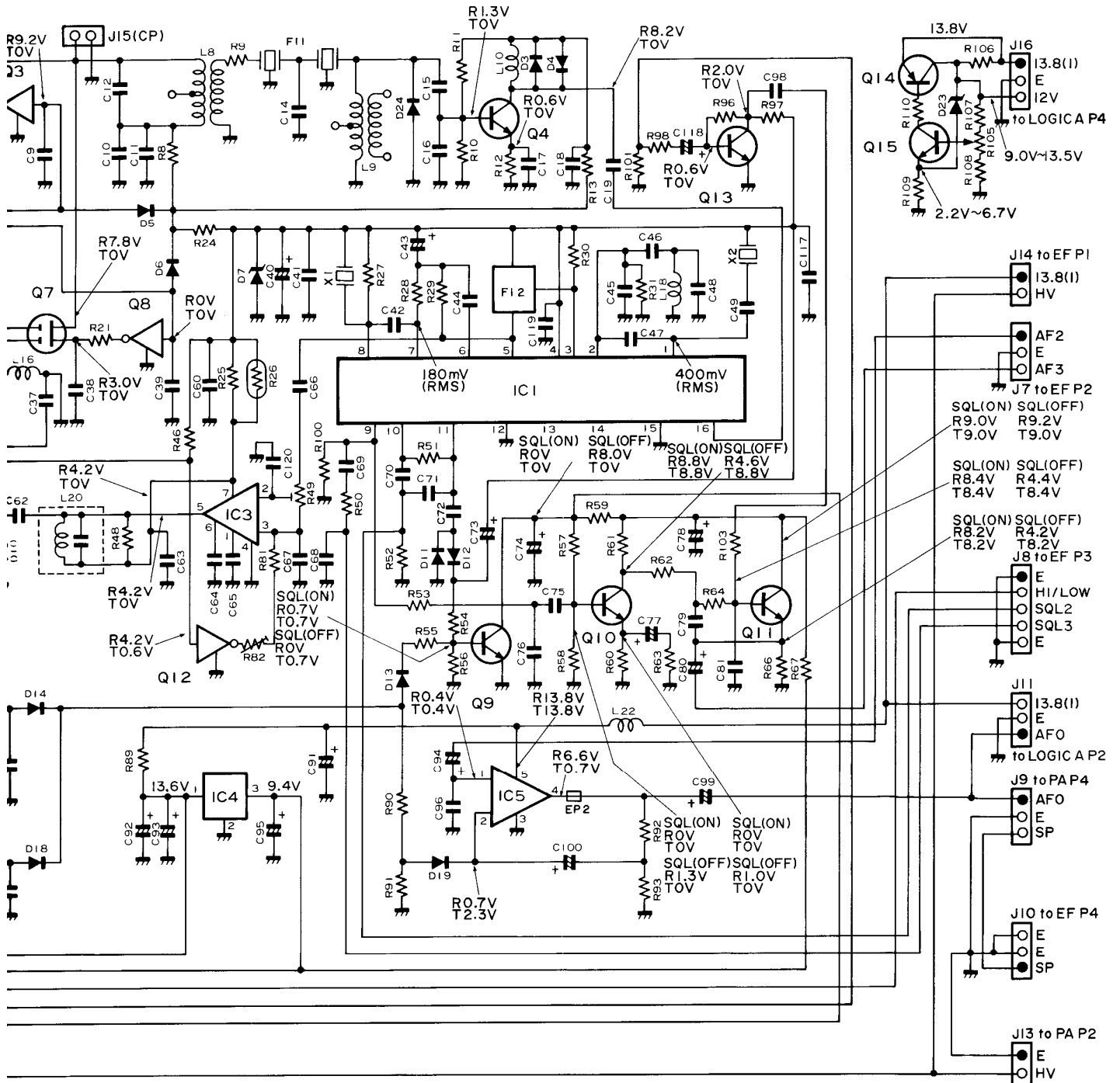

4 - 5 PLL-YGR (UHF) UNIT

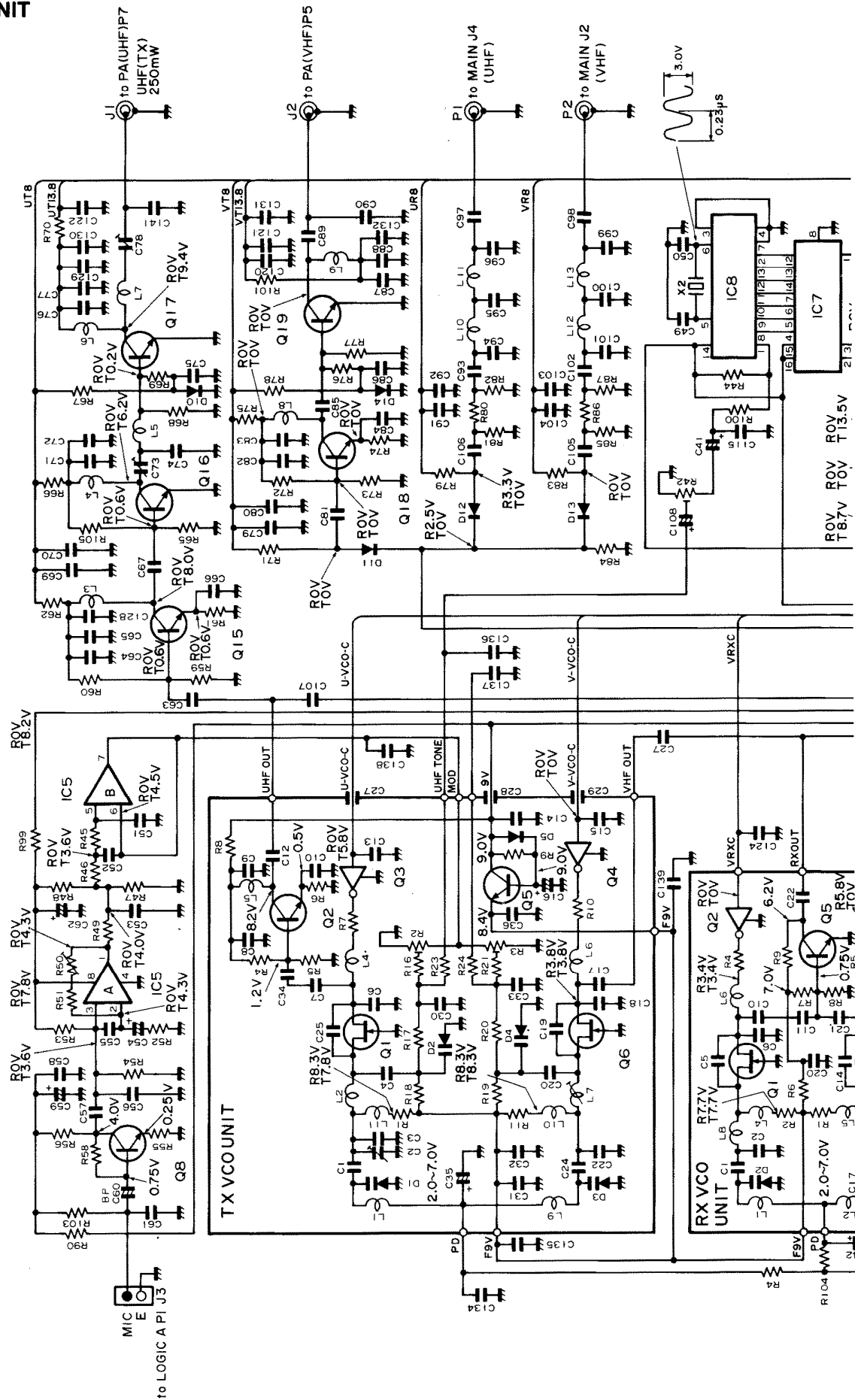

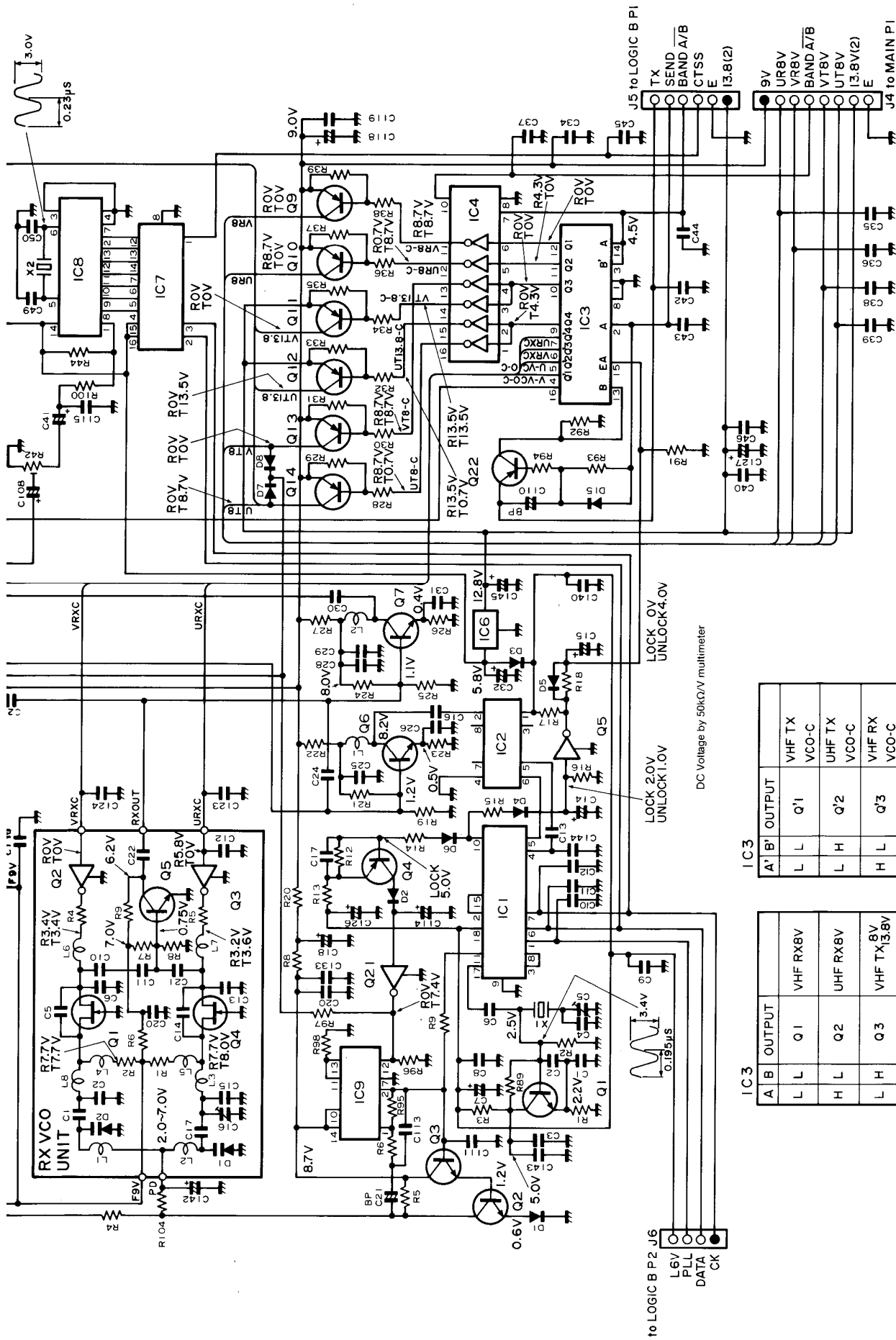

IC3

A' B' OUTPUT	Q'1	Q'2	Q'3	Q'4
L	VHF TX	VCO-C	VHF RX	VCO-C
L	VHF TX	VCO-C	VHF RX	VCO-C
L	VHF TX	VCO-C	VHF RX	VCO-C
L	VHF TX	VCO-C	VHF RX	VCO-C

IC5

A B OUTPUT	Q1	Q2	Q3	Q4
L	VHF RX8V	UHF RX8V	VHF TX13.8V	UHF TX13.8V
H	VHF RX8V	UHF RX8V	VHF TX13.8V	UHF TX13.8V
L	VHF RX8V	UHF RX8V	VHF TX13.8V	UHF TX13.8V
H	VHF RX8V	UHF RX8V	VHF TX13.8V	UHF TX13.8V

to LOGIC B P2 J6
 L6V
 PLL
 DATA
 CK

LOCK 2.0V UNLOCK1.0V
 LOCK 0V UNLOCK4.0V
 DC Voltage by 50kΩV multimeter

4 - 6 PLL-YGR (VHF) UNIT

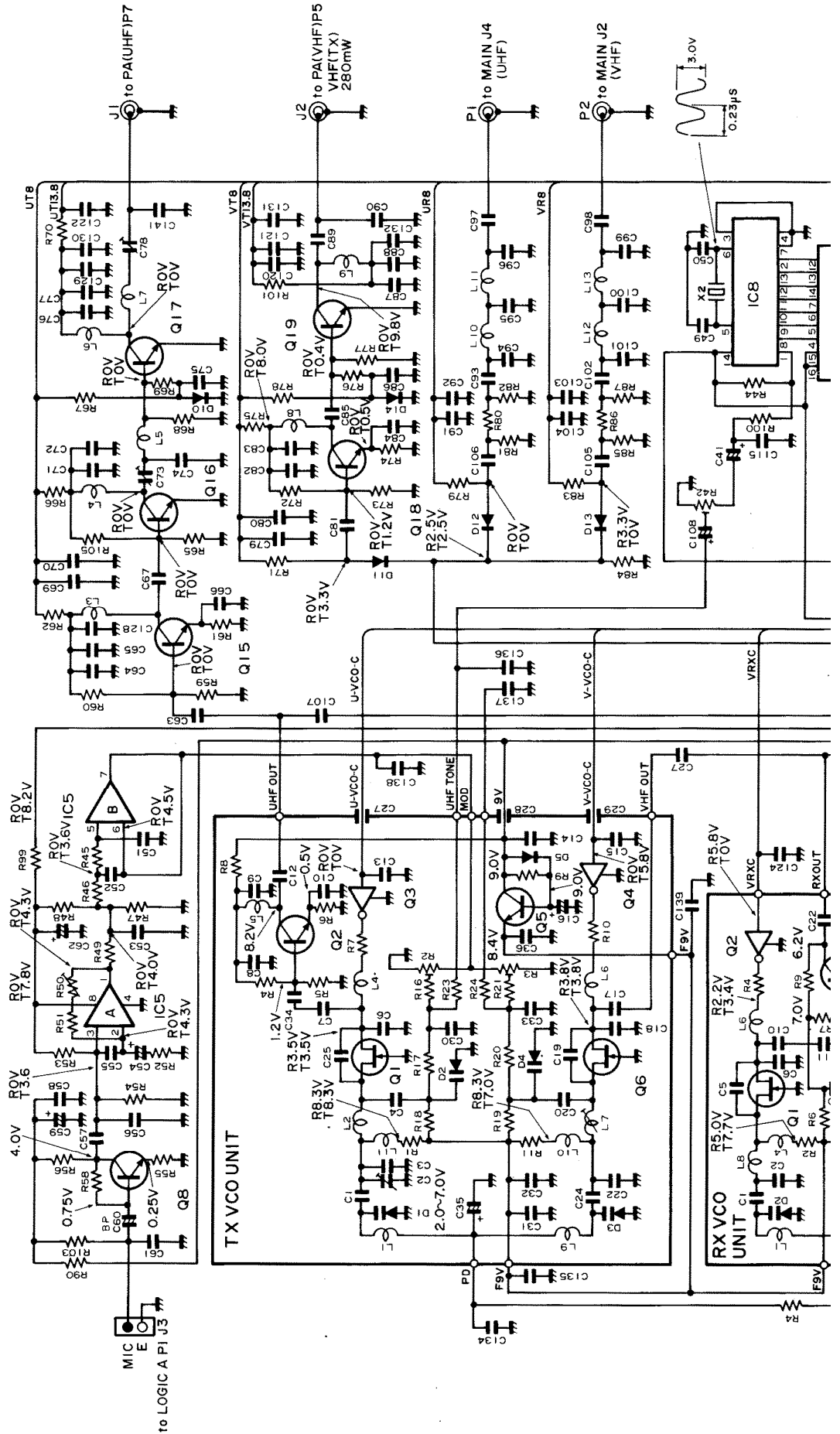

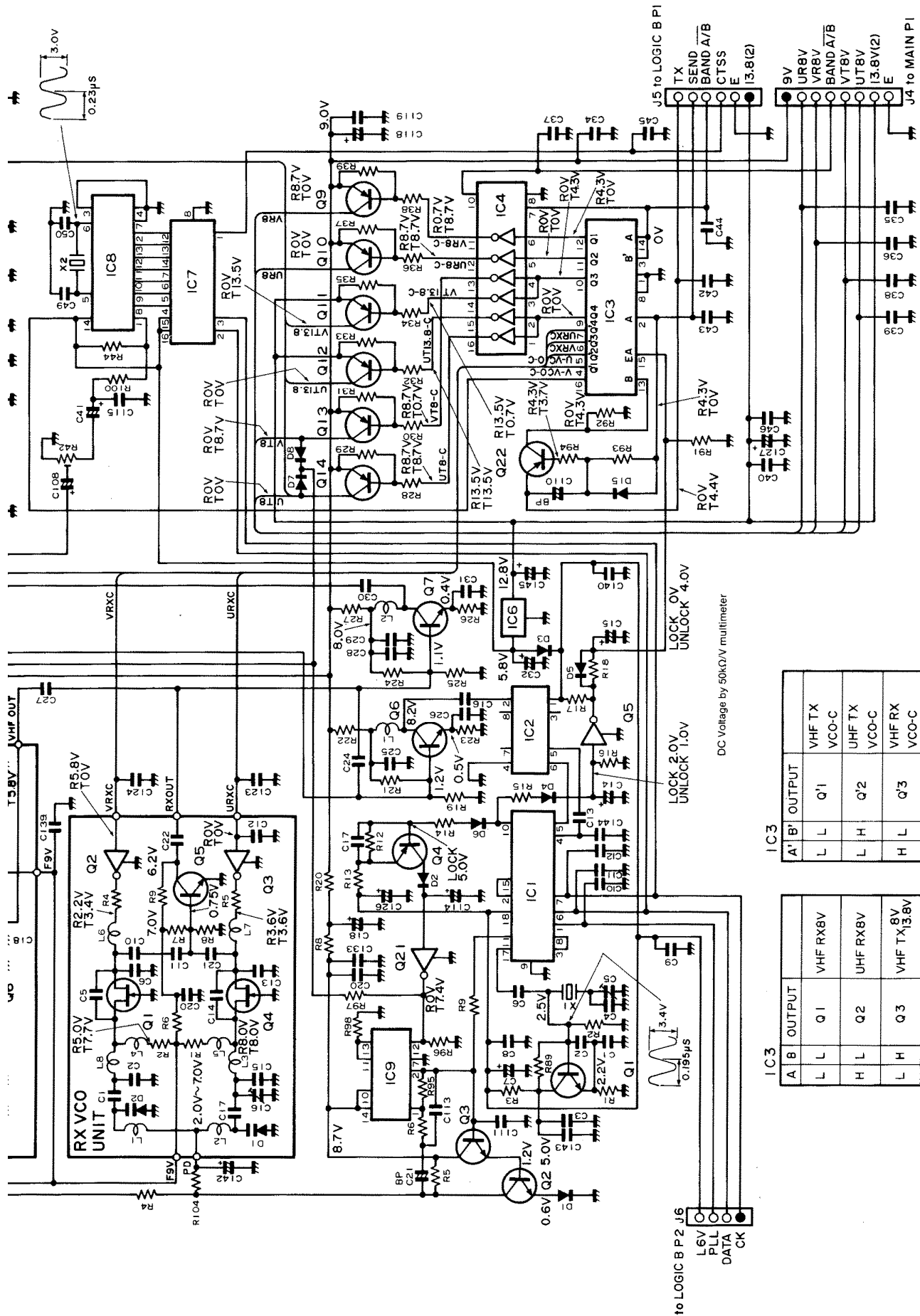

DC Voltage by 50kΩ/V multimeter

to LOGIC B P 2 J6
 LV
 PLL
 DATA
 CK

LOCK 2.0V UNLOCK 1.0V

LOCK 0V UNLOCK 4.0V

IC3

A	B	OUTPUT
L	L	Q1
H	L	Q2
L	H	Q3
H	H	Q4

IC3

A'	B'	OUTPUT
L	L	VHF TX VCO-C
L	H	UHF TX VCO-C
H	L	VHF RX VCO-C
H	H	UHF RX VCO-C

4-7 LOGIC A UNIT

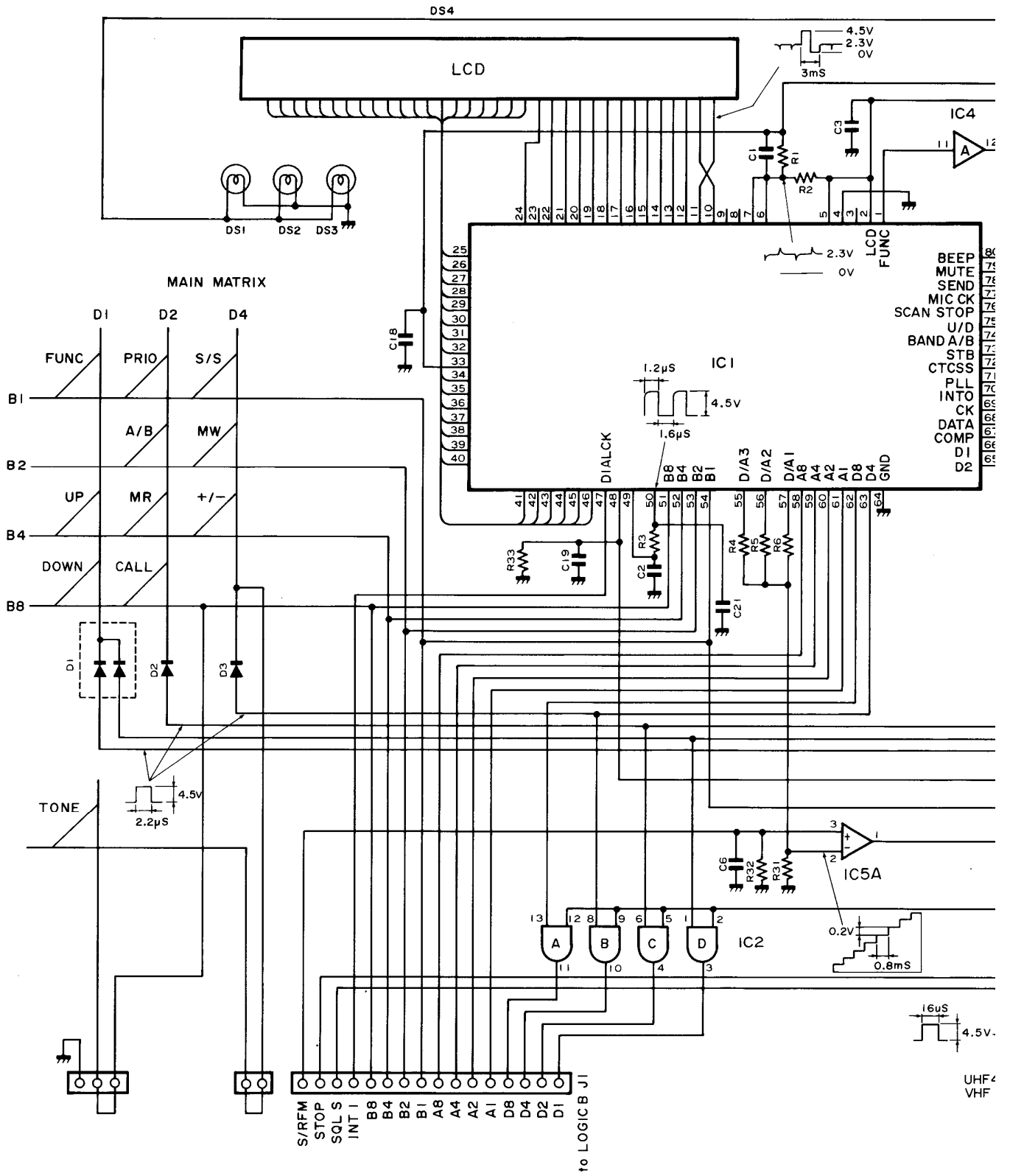

4 - 8 LOGIC B UNIT

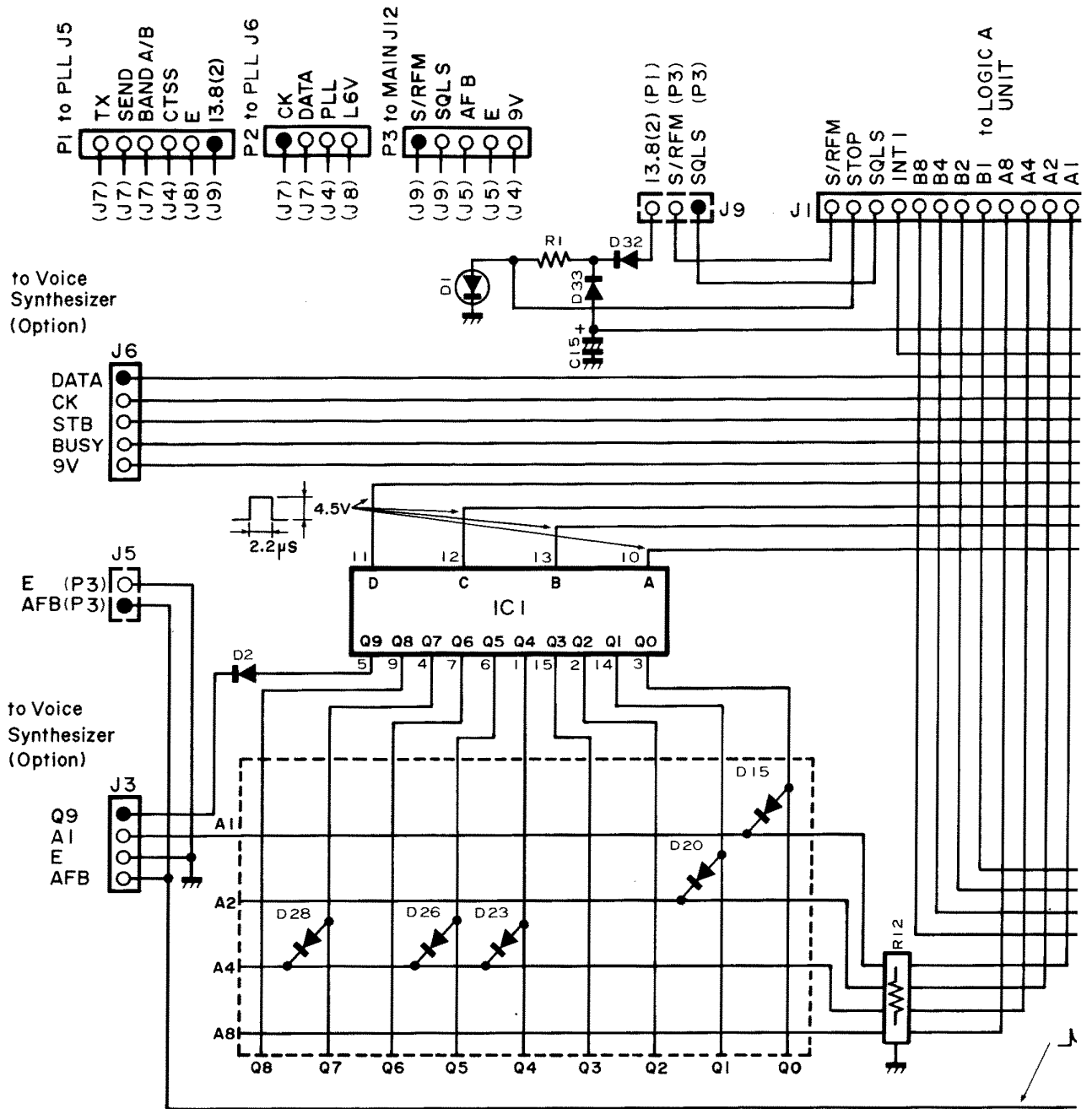

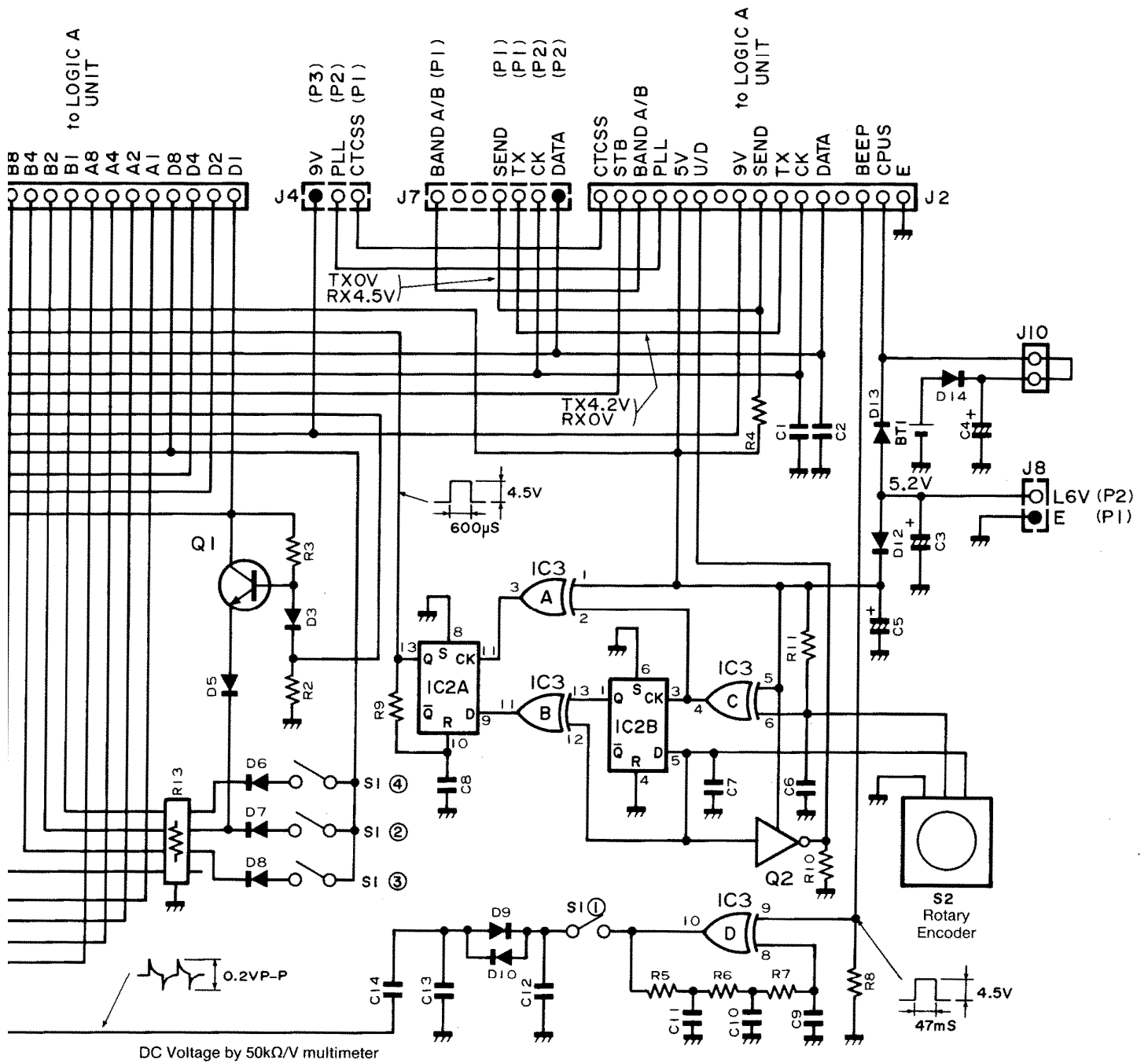

SECTION 5 MAINTENANCE AND ADJUSTMENT

5 - 1 PREPARATION BEFORE SERVICING

1. Detach the power cord and turn OFF the VOLUME/POWER CONTROL before performing any work on the transceiver.
2. Do not short circuit components while making adjustments.
3. Use an insulated tuning tool for all adjustments.
4. Do not force any of the variable components. Tune them slowly and smoothly.
5. Follow the instructions exactly. If an indicated result is not obtained, repeat the instruction until the correct result is obtained.
6. Check the condition of connectors, solder joints and screws when adjustments are complete. Confirm that components do not touch each other.
7. Confirm defective operation of the transceiver first when checking an out-of-service unit. Verify that external sources do not cause the problem.
8. Use the correct tools and test equipment.
9. Remove the transceiver case as shown in SECTION 8-1.
10. Attach a 13.8 volt DC external power source to the power supply connector. Be sure to check the polarity.
11. For transmission problems, attach a dummy load to the antenna connector. For reception problems, attach an antenna or signal generator to the antenna connector. Do not transmit into the signal generator.
12. Recheck for the suspected malfunction with the VOLUME/POWER CONTROL ON.
13. Check the defective circuit. Measure the DC voltages of the collector, base and emitter of each transistor.

5 - 2 PLL ADJUSTMENT

TEST INSTRUMENTS REQUIRED	MEASUREMENT CONNECTION LOCATION
<p>(1) VOLTAGE REGULATED POWER SUPPLY</p> <ul style="list-style-type: none"> • Output voltage : 13.8V DC \pm15% • Current capacity : 10A or more <p>(2) FREQUENCY COUNTER</p> <ul style="list-style-type: none"> • Frequency minimum : 0.1 ~ 470MHz • Frequency accuracy : 1ppm or better • Sensitivity : 100mV or better <p>(3) VOLTMETER</p> <ul style="list-style-type: none"> • Input impedance : 50kΩ/V DC or better <p>(4) RF POWER METER</p> <ul style="list-style-type: none"> • Terminated type • Minimum power rating : 150W • Frequency minimum : 30MHz • Input impedance : 50Ω • SWR : 1:1.2 or better 	

ADJUSTMENT	ADJUSTMENT CONDITIONS	MEASUREMENT		VALUE	ADJUSTMENT POINT		
		UNIT	LOCATION		UNIT	ADJUST	
VCO CONTROL VOLTAGE Ⓐ VHF BAND (BAND A) IC-3200A (USA)	1	PLL	• Frequency display: 144.00MHz • Receive mode	Connect a voltmeter to R104.	2.0V	RX VCO (PLL)	L8
	2		• Frequency display: 144.00MHz • Transmit mode	Connect a voltmeter to R4.	2.5V	TX VCO (PLL)	L7
Ⓑ UHF BAND (BAND B) IC-3200A (USA)	1	PLL	• Frequency display: 440.00MHz • Receive mode	Connect a voltmeter to R104.	2.0V	RX VCO (PLL)	C16
	2		• Frequency display: 440MHz • Transmit mode	Connect a voltmeter to R4.	2.0V	TX VCO	C2
Ⓒ VHF BAND (BAND A) IC-3200A(VK) IC-3200E	1	PLL	• Frequency display: 144.00MHz • Receive mode	Connect a voltmeter to R104.	2.0V	RX VCO	L8
	2		• Frequency display: 144.00MHz • Transmit mode	Connect a voltmeter to R4.	2.5V	TX VCO	L7
Ⓓ UHF BAND (BAND B) IC-3200A(VK) IC-3200E	1	PLL	• Frequency display: 430.00MHz • Receive mode	Connect a voltmeter to R104.	2.0V	RX VCO	C16
	2		• Frequency display: 430.00MHz • Transmit mode	Connect a voltmeter to R4.	2.0V	TX VCO	C2
FREQUENCY Ⓐ IC-3200A (USA)	1	PLL	• Frequency display: 450.00MHz • Connect a dummy load to ANTENNA CONNECTOR. • Transmit mode	Make a loose coupling between a frequency counter and the dummy load.	450.0000MHz	PLL	C5
Ⓑ IC-3200A (VK)	1		• Frequency display: 440.00MHz • Connect a dummy load to ANTENNA CONNECTOR. • Transmit mode		440.0000MHz		

PLL-YGR UNIT

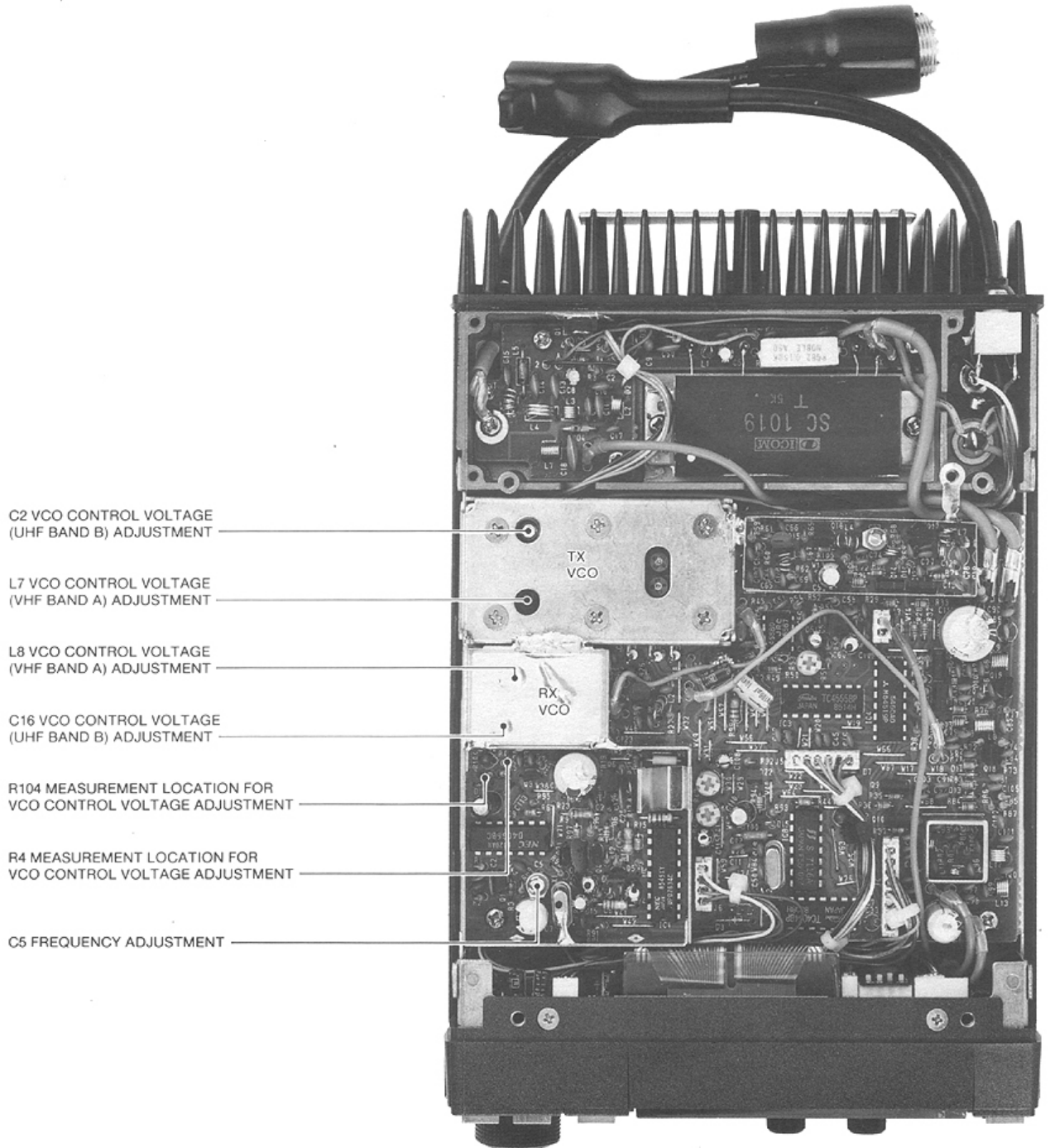

5 - 3 RECEIVER ADJUSTMENT

TEST INSTRUMENTS REQUIRED		MEASUREMENT CONNECTION LOCATION				
(1) VOLTAGE REGULATED POWER SUPPLY • Output voltage : 13.8V DC \pm 15% • Current capacity : 10A or more (2) VOLTMETER • Input impedance : 50k Ω /V DC or better (3) SINAD METER (4) RF SIGNAL GENERATOR • Frequency range : 0.1 ~ 30 MHz • Output level : 0.1 μ V ~ 100mV (5) EXTERNAL SPEAKER • Impedance : 8 Ω						
ADJUSTMENT	ADJUSTMENT CONDITIONS	MEASUREMENT			ADJUSTMENT POINT	
		UNIT	LOCATION	VALUE	UNIT	ADJUST
TOTAL GAIN Ⓐ VHF BAND	<ul style="list-style-type: none"> • Frequency display IC-3200A: 146.10MHz IC-3200E: 145.10MHz • SQUELCH CONTROL: Maximum CCW • Apply RF signal to ANTENNA CONNECTOR. Level: 32μV (-77dBm) Dev.: \pm5kHz Mod.: 1kHz 	MAIN	Connect a voltmeter to cathode of D9.	Maximum level	MAIN	L6 L20
						Ⓑ UHF BAND
Ⓒ UHF BAND	Adjustment conditions are same as above.	EXTERNAL SPEAKER JACK	Connect a SINAD meter to the EXTERNAL SPEAKER JACK.	Less than -12dB		L8 L9
NOTE: An RF helical cavity consisting of L1~L5 for the VHF BAND or L13 and L15 for the UHF BAND has been thoroughly pre-adjusted at the factory. If you need to have this component adjusted or re-adjusted, please contact any authorized ICOM dealer or ICOM Service Center since making this adjustment requires a sweep generator.						

ADJUSTMENT	ADJUSTMENT CONDITIONS	MEASUREMENT		VALUE	ADJUSTMENT POINT	
		UNIT	LOCATION		UNIT	ADJUST
S-LEVEL METER Ⓐ VHF BAND	<ul style="list-style-type: none"> • Frequency display IC-3200A: 146.10MHz IC-3200E: 145.10MHz • SQUELCH CONTROL: Maximum CCW • Apply RF signal to ANTENNA CONNECTOR. Level: 1μV (-107dBm) Dev.: ±5kHz Mod.: 1kHz 	DISPLAY	 <p>2 bars Either VFO A or M appears</p>	2 bars appear on the DISPLAY.	MAIN	R82
						Ⓑ UHF BAND

MAIN UNIT

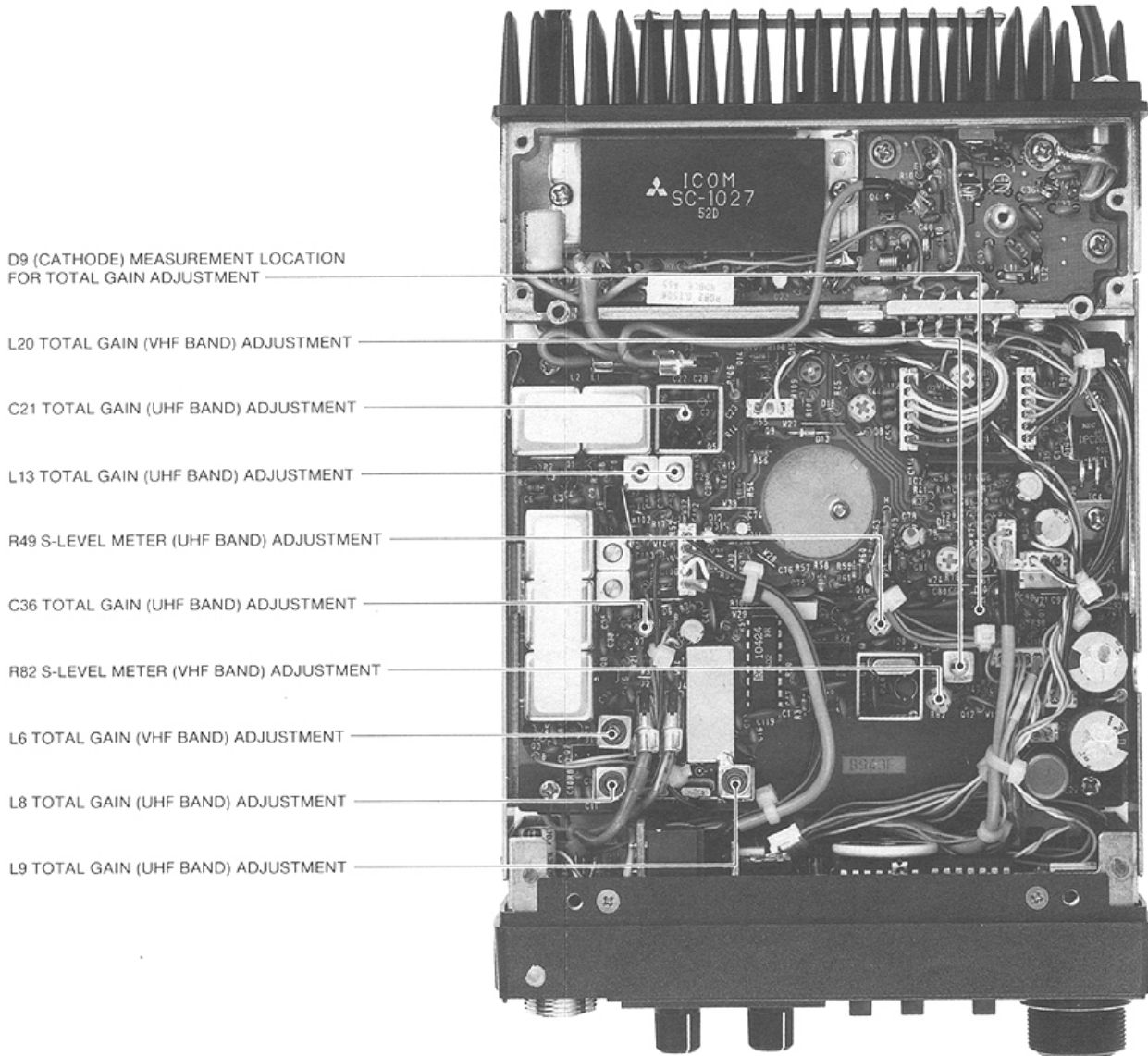

5 - 4 TRANSMITTER (UHF BAND) ADJUSTMENT

TEST INSTRUMENTS REQUIRED	MEASUREMENT CONNECTION LOCATION
<p>(1) VOLTAGE REGULATED POWER SUPPLY</p> <ul style="list-style-type: none"> • Output voltage : 13.8V DC \pm15% • Current capacity : 10A or more <p>(2) POWER METER</p> <ul style="list-style-type: none"> • Terminated type • Minimum power rating : 150W • Frequency minimum : 30MHz • Input impedance : 50Ω • SWR : 1:1.2 or better <p>(3) RF VOLTMETER</p> <ul style="list-style-type: none"> • Frequency minimum : 80MHz • Measuring range : 0.01V ~ 10V <p>(4) DEVIATION METER</p> <ul style="list-style-type: none"> • Frequency minimum : 30MHz • Measuring range : 0 ~ \pm5kHz • De-emphasis : OFF 	<p style="text-align: center;">IC-3200A/E</p>

ADJUSTMENT	ADJUSTMENT CONDITIONS	MEASUREMENT		VALUE	ADJUSTMENT POINT	
		UNIT	LOCATION		UNIT	ADJUST
OUTPUT POWER	1 <ul style="list-style-type: none"> • Frequency display IC-3200A: 445.00MHz IC-3200E: 435.00MHz • Output power: HIGH • R42 (MAIN UNIT): Maximum CW • Transmit mode 	PLL	Unplug P7 from J1 and connect a power meter or an RF voltmeter to J1.	Maximum output level. The output level should be more than 200mW or +23dBm.	PLL	C73 C78
ALC	2 <ul style="list-style-type: none"> • Output power: HIGH 	ANTENNA CONNECTOR	Connect a power meter to ANTENNA CONNECTOR.	25W	MAIN	R42
	3 <ul style="list-style-type: none"> • Output power: LOW 			5W		
RF LEVEL INDICATOR	1 <ul style="list-style-type: none"> • Frequency display IC-3200A: 445.00MHz IC-3200E: 435.00MHz • Output power: LOW • Transmit mode 	DISPLAY	<p style="text-align: center;">3 bars</p>	Three bars appear on the DISPLAY.	MAIN	R88
MODULATION ① IC-3200A VERSIONS	1 <ul style="list-style-type: none"> • Frequency display IC-3200A (USA) : 445.00MHz IC-3200A (VK) : 435.00MHz • TONE: OFF • Apply AF signal to MIC CONNECTOR. Level: 65mV Freq.: 1kHz • Transmit mode 	ANTENNA CONNECTOR	Connect a deviation meter to ANTENNA CONNECTOR. See SECTION 3-2-2 for MIC CONNECTOR CONNECTIONS.	\pm 4.8kHz	TX VCO	R2

ADJUSTMENT	ADJUSTMENT CONDITIONS	MEASUREMENT		VALUE	ADJUSTMENT POINT		
		UNIT	LOCATION		UNIT	ADJUST	
⑥ IC-3200E VERSION	2	<ul style="list-style-type: none"> Reduce 20dB for the input AF signal level. Level: 6.5mV Freq.: 1kHz 			±3.5kHz	PLL	R50
	1	<ul style="list-style-type: none"> Frequency display: 435.00MHz TONE: OFF Apply AF signal to MIC CONNECTOR. Level: 20mV Freq.: 1kHz Transmit mode 			±4.8kHz	TX VCO	R2
	2	<ul style="list-style-type: none"> Reduce 20dB for the input AF signal level. Level: 2mV Freq.: 1kHz 			±3.5kHz	PLL	R50
SUBAUDIBLE TONE DEVIATION ④ IC-3200A VERSIONS	1	<ul style="list-style-type: none"> Frequency display: 445.00MHz TONE: ON TONE No.: 08 (88.5Hz) Apply no signal to MIC CONNECTOR. Transmit mode 	ANTENNA CONNECTOR	Connect a deviation meter to ANTENNA CONNECTOR.	±0.7kHz	PLL	R42
⑥ IC-3200E VERSION	1	<ul style="list-style-type: none"> Frequency display: 435.00MHz [TONE] SWITCH: Push Apply no signal to MIC CONNECTOR. 			±3.5kHz		R42

PLL-YGR UNIT

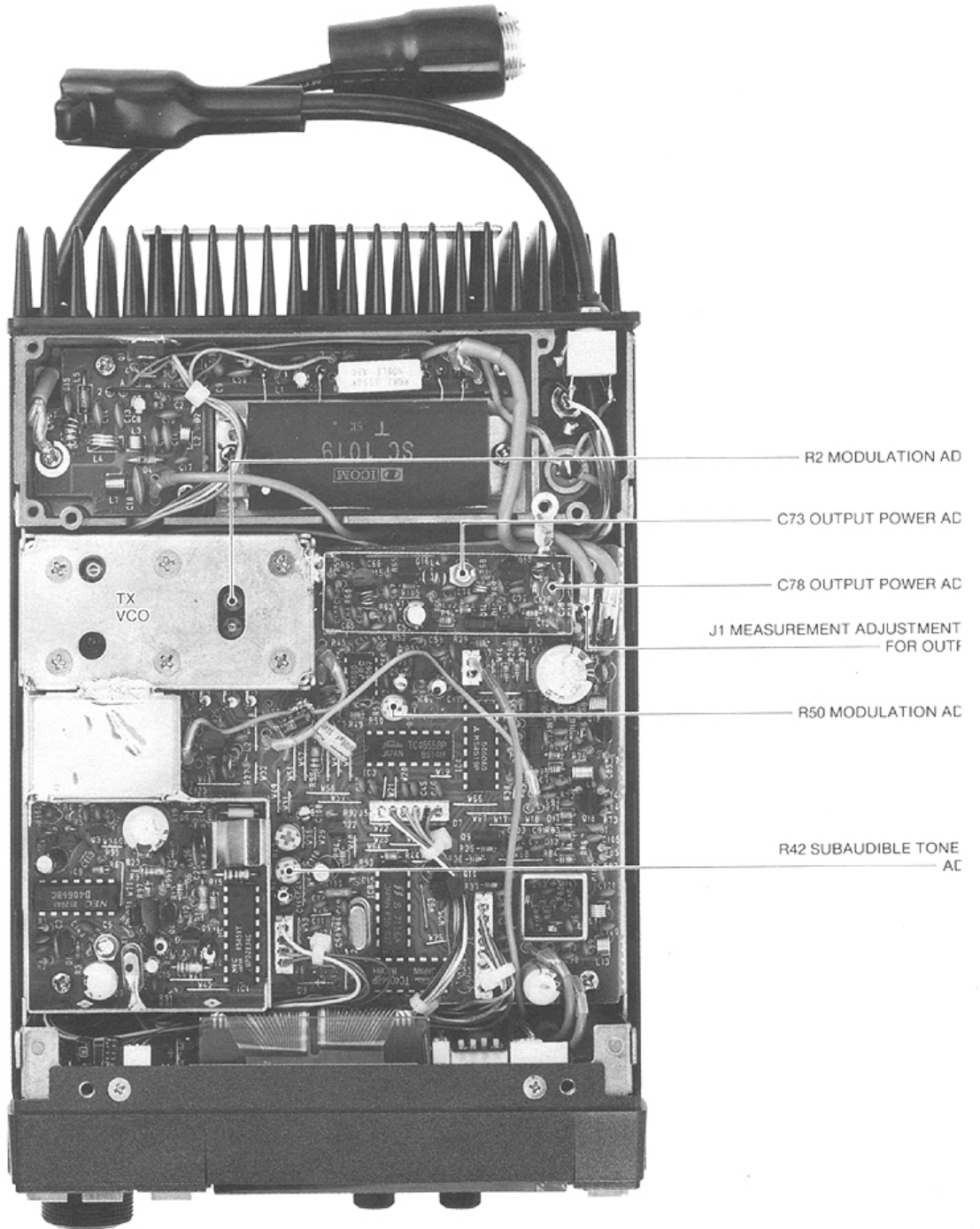

MAIN UNIT

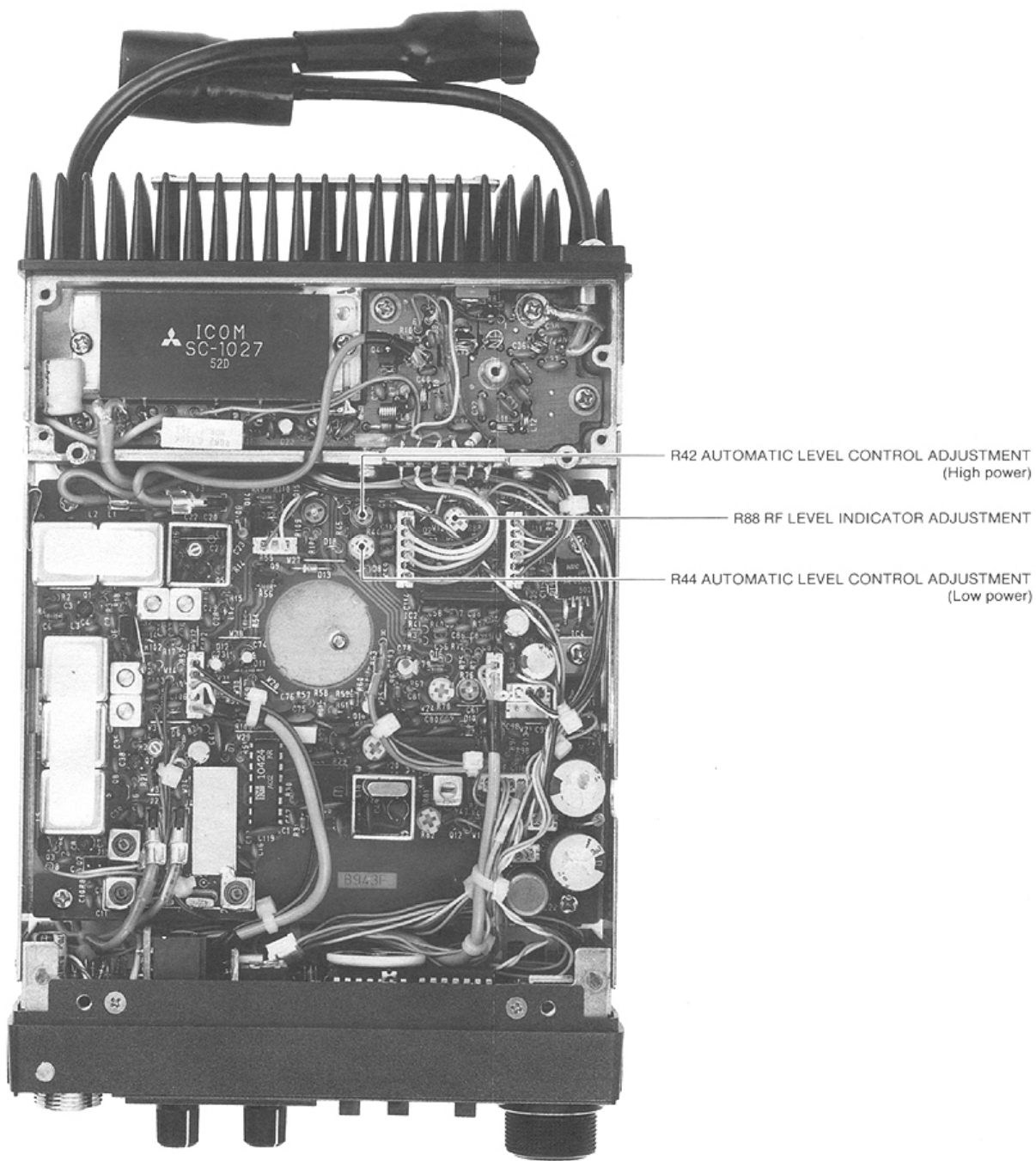

5 - 5 TRANSMITTER (VHF BAND) ADJUSTMENT

TEST INSTRUMENTS REQUIRED	MEASUREMENT CONNECTION LOCATION
<p>(1) VOLTAGE REGULATED POWER SUPPLY</p> <ul style="list-style-type: none"> • Output voltage : 13.8V DC \pm15% • Current capacity : 10A or more <p>(2) RF VOLTMETER</p> <ul style="list-style-type: none"> • Frequency minimum : 80MHz • Measuring range : 0.01V ~ 10V <p>(3) POWER METER</p> <ul style="list-style-type: none"> • Terminated type • Minimum power rating : 150W • Frequency minimum : 30MHz • Input impedance : 50Ω • SWR : 1:1.2 or better <p>(4) DEVIATION METER</p> <ul style="list-style-type: none"> • Frequency minimum : 30MHz • Measuring range : 0 ~ \pm5kHz • De-emphasis : OFF 	<p>The diagram illustrates the measurement setup for the IC-3200A/E transmitter. It shows an AC Power Supply connected to the transmitter. A Power Meter is connected to the antenna connector (ANT.). A Deviation Meter is connected to the antenna connector (ANT.). An RF Voltmeter is connected to the J2 connector. The PLL-YGR Unit is also shown.</p>

ADJUSTMENT	ADJUSTMENT CONDITIONS	MEASUREMENT			ADJUSTMENT POINT	
		UNIT	LOCATION	VALUE	UNIT	ADJUST
OUTPUT POWER	1 <ul style="list-style-type: none"> • Frequency display IC-3200A: 146.01MHz IC-3200E: 145.00MHz • Output power: HIGH • Transmit mode 	PLL	Unplug P5 from J2 and connect a power meter or RF voltmeter to J2.	More than 200mW or +23dBm	PLL	Verify
ALC	2 <ul style="list-style-type: none"> • Output power: HIGH 	ANTENNA CONNECTOR	Connect a power meter to ANTENNA CONNECTOR.	25W	MAIN	R76
	3 <ul style="list-style-type: none"> • Output power: LOW 			5W		R78
RF LEVEL INDICATOR	1 <p>NOTE: No adjustment is required if this adjustment has already been made in the UHF band. Refer to SECTION 5-4 TRANSMITTER (UHF BAND) ADJUSTMENT for RF LEVEL INDICATOR instructions.</p>					
MODULATION ① IC-3200A VERSIONS	1 <ul style="list-style-type: none"> • Frequency display: 146.00MHz • TONE: OFF • Apply AF signal to MIC CONNECTOR. Level: 65mV Freq.: 1kHz • Transmit mode 	ANTENNA CONNECTOR	Connect a deviation meter to ANTENNA CONNECTOR. See SECTION 3-2-2 for MIC CONNECTOR CONNECTIONS.	\pm 4.8kHz	TX VCO	R3
	2 <ul style="list-style-type: none"> • Reduce 20dB for the input AF signal level. Level: 6.5mV Freq.: 1kHz 			\pm 3.5kHz		Verify
② IC-3200E VERSION	1 <ul style="list-style-type: none"> • Frequency display: 145.00MHz • TONE: OFF • Apply AF signal to MIC CONNECTOR. Level: 20mV Freq.: 1kHz • Transmit mode 			\pm 4.8kHz		R3
	2 <ul style="list-style-type: none"> • Reduce 20dB for the input AF signal level. Level: 2mV Freq.: 1kHz 			\pm 3.5kHz		Verify
SUBAUDIBLE TONE DEVIATION ① IC-3200A VERSION	1 <ul style="list-style-type: none"> • Frequency display: 146.00MHz • TONE: ON • TONE No.: 08 (88.5Hz) • No signal applies to MIC CONNECTOR. 	ANTENNA CONNECTOR	Connect a deviation meter to ANTENNA CONNECTOR.	\pm 0.7kHz	PLL	R43
	② IC-3200E VERSION			1 <ul style="list-style-type: none"> • Frequency display: 145.00MHz • [TONE] SWITCH: Push • Apply no signal to MIC CONNECTOR. 		\pm 3.5kHz

PLL-YGR UNIT

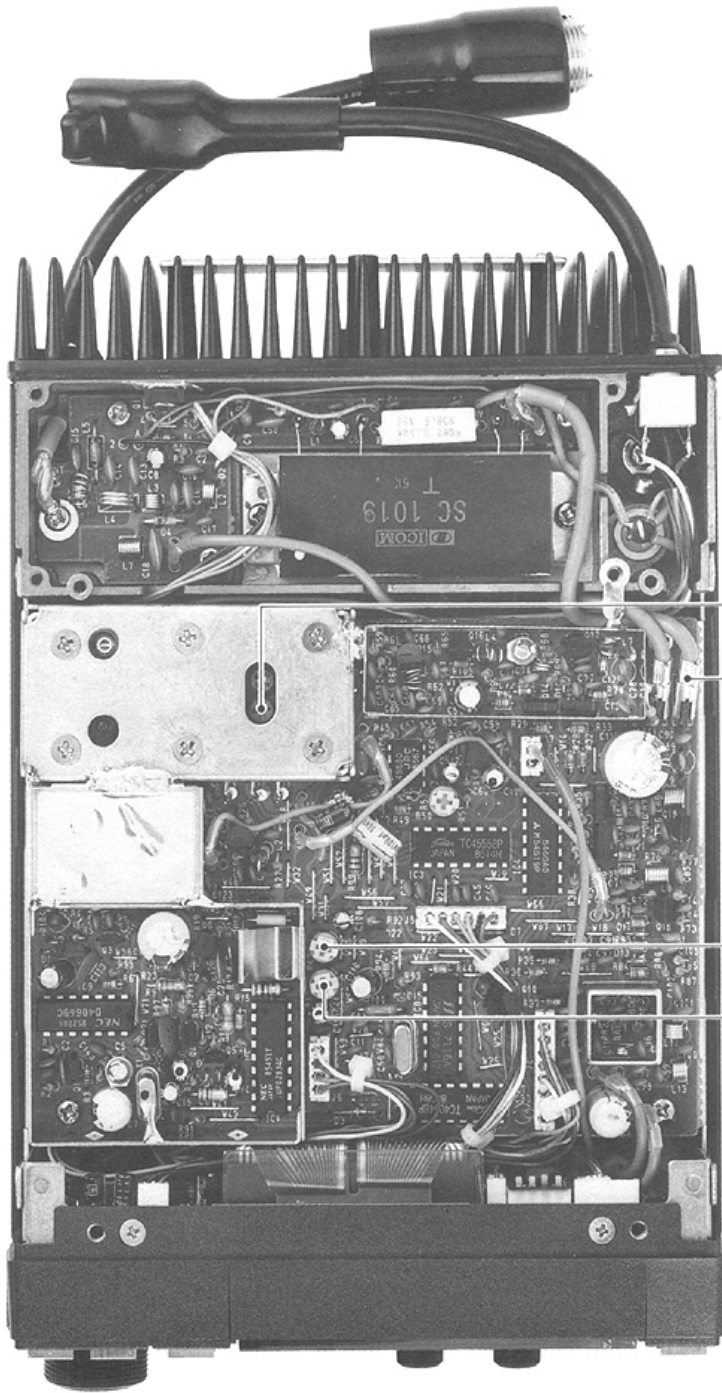

R3 MODULATION ADJUSTMENT

J2 MEASUREMENT LOCATION FOR
OUTPUT POWER ADJUSTMENT

R43 SUBAUDIBLE TONE DEVIATION
ADJUSTMENT

R42 SUBAUDIBLE TONE DEVIATION
ADJUSTMENT

MAIN UNIT

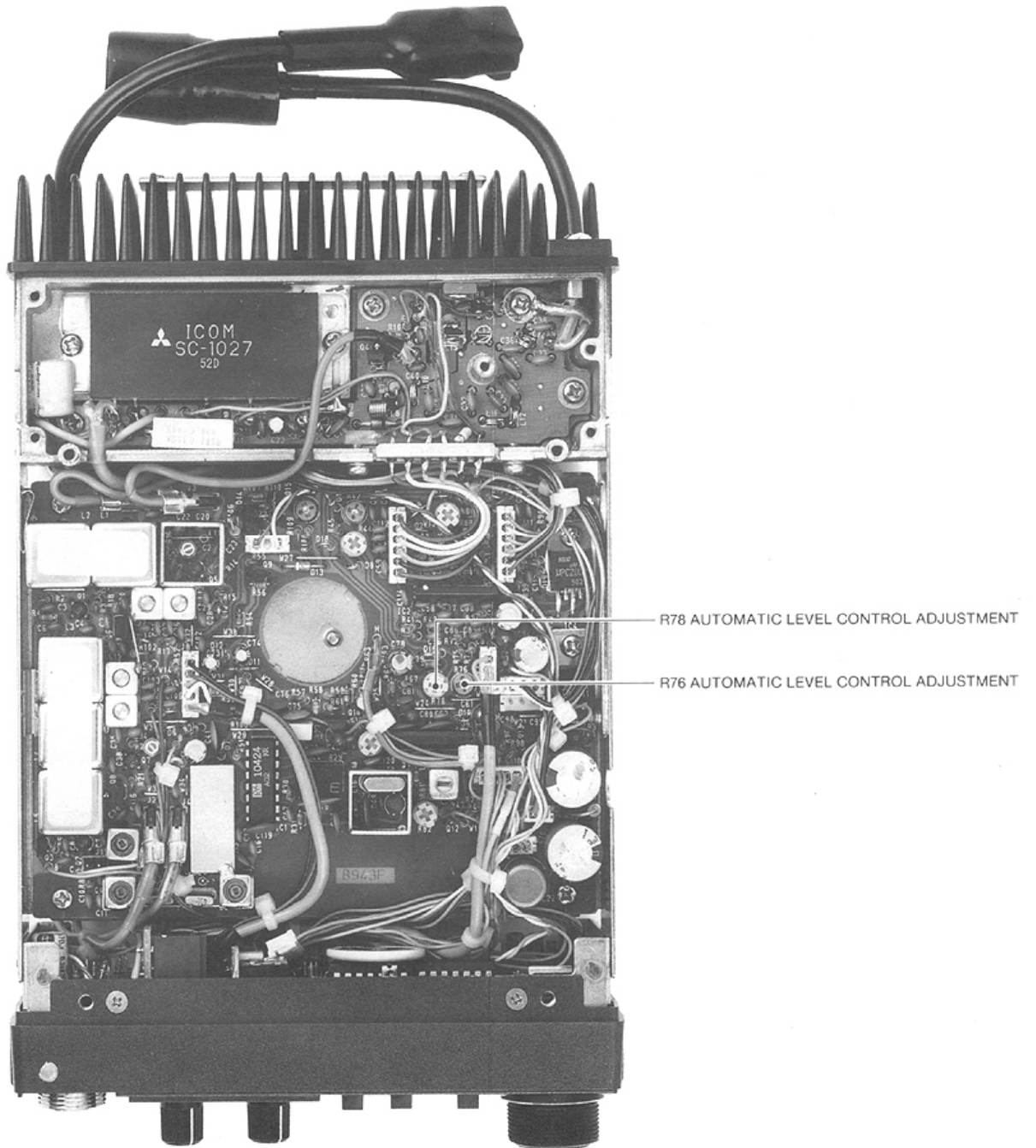

SECTION 6 TROUBLESHOOTING

Your IC-3200A/E has been carefully adjusted at the factory prior to shipping. The chart below is provided to help you correct problems that are not equipment malfunctions.

If you are unable to locate the trouble or correct the fault, please contact your dealer or the nearest authorized ICOM Service Center.

PROBLEM	POSSIBLE CAUSE	SOLUTION
1. Power does not come on when the POWER SWITCH is pressed.	<ul style="list-style-type: none"> • Power cable is improperly connected. • Power cable is connected with the polarity reversed. • Power supply connection is impaired. • Power supply is not connected. • Blown fuse. 	<ul style="list-style-type: none"> • Carefully reconnect power cable. • Disconnect the power cable, replace fuse, and reconnect the power cable observing the proper polarity. • Inspect connection pins. • Reconnect. • Check for the cause, then replace fuse with a spare one.
2. No sound comes from the speaker.	<ul style="list-style-type: none"> • VOLUME CONTROL is turned completely counterclockwise but not "clicked" OFF. • SQUELCH CONTROL is operating. • Internal speaker is disconnected. • Connection cable to the optional external speaker is broken. 	<ul style="list-style-type: none"> • Turn the control clockwise to a suitable level. • Turn the SQUELCH CONTROL completely counterclockwise. • Inspect and make connection. • Inspect and repair connection.
3. Sensitivity is low and only strong signals are audible.	<ul style="list-style-type: none"> • The antenna feedline is cut or shorted. • Receive frequency and the receivable frequency range of the antenna are not compatible. 	<ul style="list-style-type: none"> • Check the feedline and correct any improper condition. • Change antennas.
4. RF output is low or non-existent.	<ul style="list-style-type: none"> • The PTT SWITCH is impaired due to a poor connection with the MIC CONNECTOR. • The antenna feedline is cut or shorted. 	<ul style="list-style-type: none"> • Check MIC CONNECTOR connection. • Check the antenna feedline for problems.
5. No modulation.	<ul style="list-style-type: none"> • Poor MIC CONNECTOR connection. • The MIC cable is cut. 	<ul style="list-style-type: none"> • Check connections at the MIC CONNECTOR and correct any problems. • Repair disconnected or cut wires.
6. Unable to contact another station even though signals are being transmitted and the receive mode function is working.	<ul style="list-style-type: none"> • The transceiver is set in DUPLEX mode (when SIMPLEX is desired) or vice versa. • An improper frequency split is programmed or input/output repeater frequencies are reversed. 	<ul style="list-style-type: none"> • Press the [+/-] SWITCH to select SIMPLEX mode or press the [+/-] SWITCH to select either DUPLEX + or DUPLEX - mode. • Program the proper frequency split or press the [+/-] SWITCH to select either DUPLEX + or DUPLEX - mode according to the repeater input/output frequencies.
7. MEMORY SCAN mode does not function when the SCAN SWITCH is pressed.	<ul style="list-style-type: none"> • The transceiver is not set in MEMORY SCAN mode. • All memory channels are programmed with the MEMORY SKIP function. • The SQUELCH CONTROL is open (RX INDICATOR is ON). 	<ul style="list-style-type: none"> • Press the [MR] SWITCH. • Delete some of the MEMORY SKIP programming from the memory channels by pressing the [F] and [M-SKIP] SWITCHES. • Turn the SQUELCH CONTROL clockwise until the RX INDICATOR goes out.

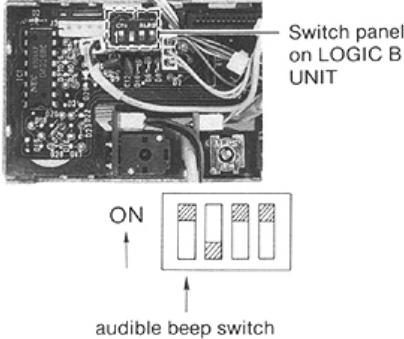
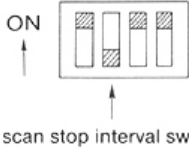
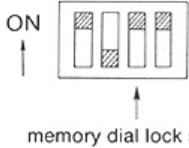
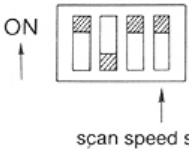
PROBLEM	POSSIBLE CAUSE	SOLUTION
8. PROGRAMMED SCAN mode does not function when the SCAN SWITCH is pressed.	<ul style="list-style-type: none"> • The transceiver is not set in the VFO mode. • The SQUELCH CONTROL is open (RX INDICATOR is ON). 	<ul style="list-style-type: none"> • Press the [A/B] SWITCH to select the VFO mode. • Turn the SQUELCH CONTROL clockwise until the RX INDICATOR goes out.
9. Frequency does not change when turning the TUNING CONTROL.	<ul style="list-style-type: none"> • LOCK SWITCH is engaged. 	<ul style="list-style-type: none"> • Press the FUNCTION [F] SWITCH and [LOCK] SWITCH to disengage the lock.
10. No voice output occurs when an optional UT-23 VOICE SYNTHESIZER unit is installed.	<ul style="list-style-type: none"> • ON/OFF SWITCH on the UT-23 is in the OFF position. • TUNING CONTROL is being rotated. 	<ul style="list-style-type: none"> • Set the ON/OFF SWITCH in the ON position after installing unit. • Stop the TUNING CONTROL at a receive frequency for voice output to be heard.
11. No beeps are heard when pressing the [▶] or [◀] SWITCHES on the front panel.	<ul style="list-style-type: none"> • The audible beep switch on the LOGIC B UNIT is in the OFF position. 	<ul style="list-style-type: none"> • Set switch to the ON position.  <p>Switch panel on LOGIC B UNIT</p> <p>ON ↑</p> <p>audible beep switch</p>
12. Scanning does not begin immediately after a signal fades.	<ul style="list-style-type: none"> • The scan stop interval switch on the LOGIC B UNIT is in the ON position. 	<ul style="list-style-type: none"> • Set switch to the OFF position.  <p>ON ↑</p> <p>scan stop interval switch</p>
13. MEMORY CHANNELS can not be recalled by turning the TUNING CONTROL.	<ul style="list-style-type: none"> • The memory dial lock switch on the LOGIC B UNIT is in the OFF position. 	<ul style="list-style-type: none"> • Set switch to the ON position.  <p>ON ↑</p> <p>memory dial lock switch</p>
14. Scanning speed is slower or faster than that desired.	<ul style="list-style-type: none"> • The scan speed switch on the LOGIC B UNIT is set in the wrong position. 	<ul style="list-style-type: none"> • Adjust the switch to select the desired scanning speed: fast [ON], slow [OFF].  <p>ON ↑</p> <p>scan speed switch</p>

SECTION 7 INSIDE VIEWS

7 - 1 MAIN UNIT

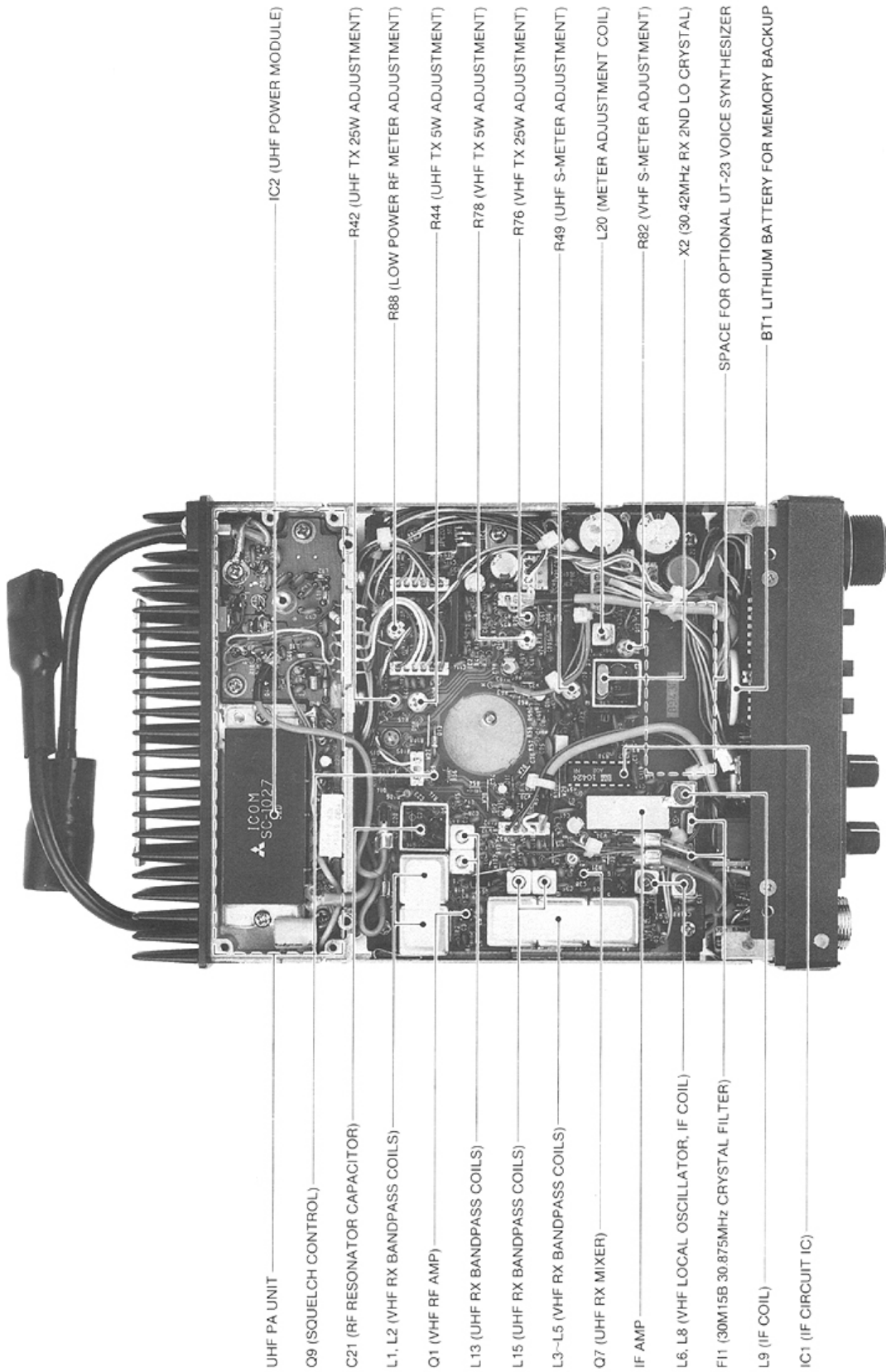

- UHF PA UNIT
- Q9 (SQUELCH CONTROL)
- C21 (RF RESONATOR CAPACITOR)
- L1, L2 (VHF RX BANDPASS COILS)
- Q1 (VHF RF AMP)
- L13 (UHF RX BANDPASS COILS)
- L15 (UHF RX BANDPASS COILS)
- L3-L5 (VHF RX BANDPASS COILS)
- Q7 (UHF RX MIXER)
- IF AMP
- L6, L8 (VHF LOCAL OSCILLATOR, IF COIL)
- F11 (30M15B 30.875MHz CRYSTAL FILTER)
- L9 (IF COIL)
- IC1 (IF CIRCUIT IC)
- IC2 (UHF POWER MODULE)
- R42 (UHF TX 25W ADJUSTMENT)
- R88 (LOW POWER RF METER ADJUSTMENT)
- R44 (UHF TX 5W ADJUSTMENT)
- R78 (VHF TX 5W ADJUSTMENT)
- R76 (VHF TX 25W ADJUSTMENT)
- R49 (UHF S-METER ADJUSTMENT)
- L20 (METER ADJUSTMENT COIL)
- R82 (VHF S-METER ADJUSTMENT)
- X2 (30.42MHz RX 2ND LO CRYSTAL)
- SPACE FOR OPTIONAL UT-23 VOICE SYNTHESIZER
- BT1 LITHIUM BATTERY FOR MEMORY BACKUP

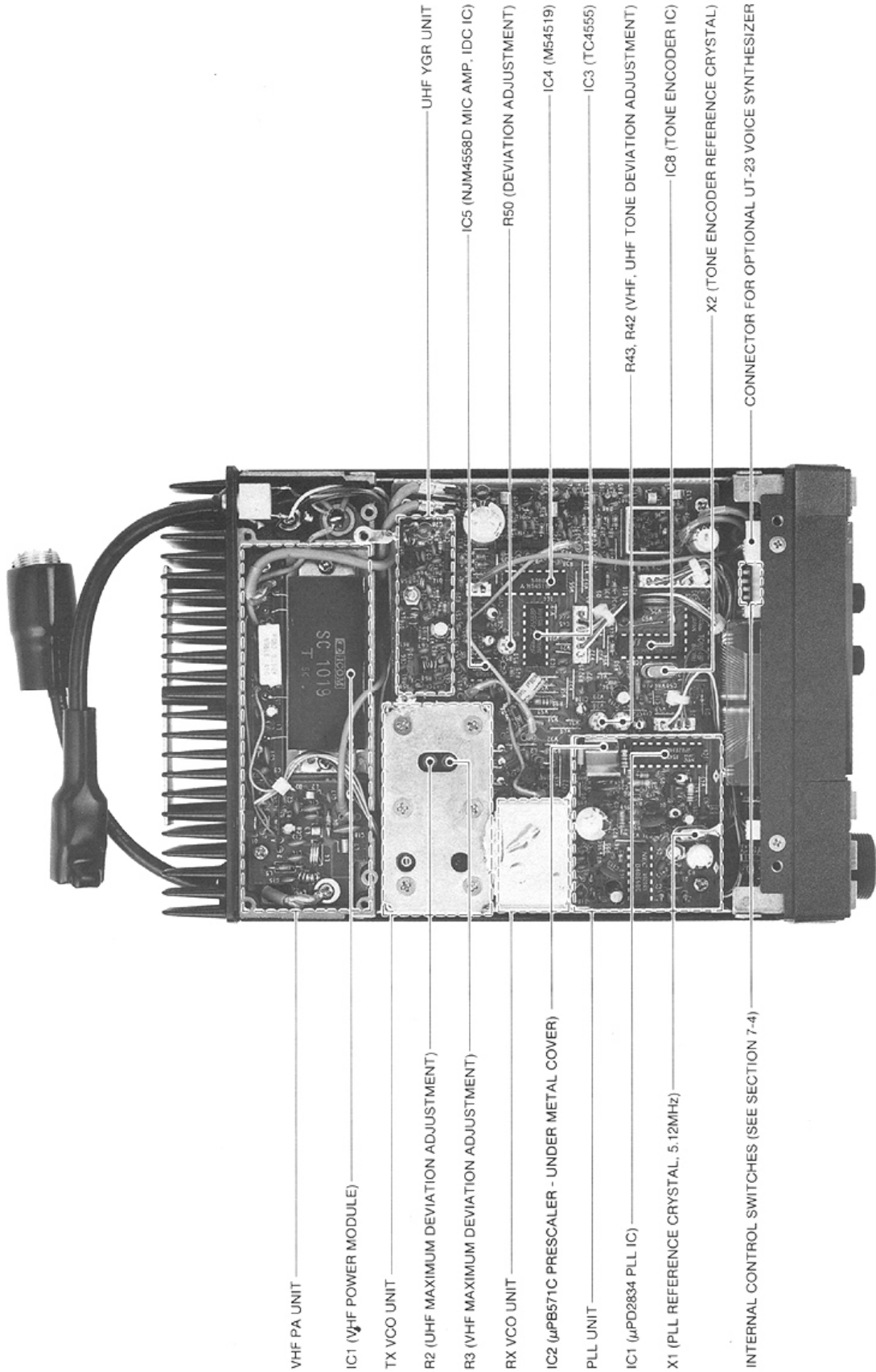

VHF PA UNIT

IC1 (VHF POWER MODULE)

TX VCO UNIT

R2 (UHF MAXIMUM DEVIATION ADJUSTMENT)

R3 (VHF MAXIMUM DEVIATION ADJUSTMENT)

RX VCO UNIT

IC2 (µPB571C PRESCALER - UNDER METAL COVER)

PLL UNIT

IC1 (µPD2834 PLL IC)

X1 (PLL REFERENCE CRYSTAL, 5.12MHz)

INTERNAL CONTROL SWITCHES (SEE SECTION 7-4)

UHF YGR UNIT

IC5 (NJM4558D MIC AMP. IDC IC)

R50 (DEVIATION ADJUSTMENT)

IC4 (M54519)

IC3 (TC4555)

R43, R42 (VHF, UHF TONE DEVIATION ADJUSTMENT)

IC8 (TONE ENCODER IC)

X2 (TONE ENCODER REFERENCE CRYSTAL)

CONNECTOR FOR OPTIONAL UT-23 VOICE SYNTHESIZER

7 - 3 PLL-YGR UNIT (IC-3200E)

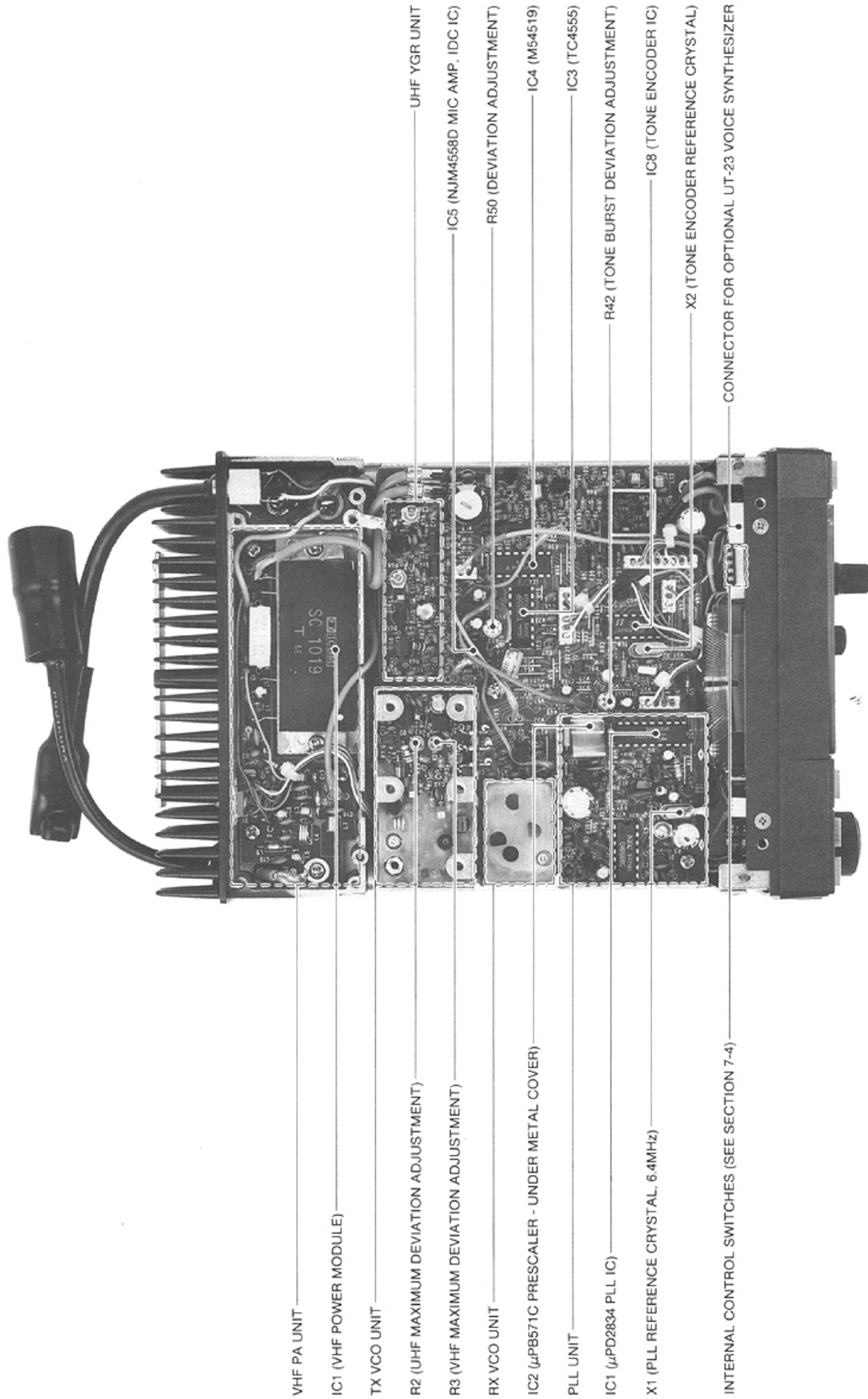

VHF PA UNIT

IC1 (VHF POWER MODULE)

TX VCO UNIT

R2 (UHF MAXIMUM DEVIATION ADJUSTMENT)

R3 (VHF MAXIMUM DEVIATION ADJUSTMENT)

RX VCO UNIT

IC2 (μ PB571C PRESCALER - UNDER METAL COVER)

PLL UNIT

IC1 (μ PD2834 PLL IC)

X1 (PLL REFERENCE CRYSTAL, 6.4MHz)

INTERNAL CONTROL SWITCHES (SEE SECTION 7-4)

UHF YGR UNIT

IC5 (NJM4558D MIC AMP. IDC IC)

R50 (DEVIATION ADJUSTMENT)

IC4 (M54519)

IC3 (TC4555)

R42 (TONE BURST DEVIATION ADJUSTMENT)

IC8 (TONE ENCODER IC)

X2 (TONE ENCODER REFERENCE CRYSTAL)

CONNECTOR FOR OPTIONAL UT-23 VOICE SYNTHESIZER

LOGIC A UNIT

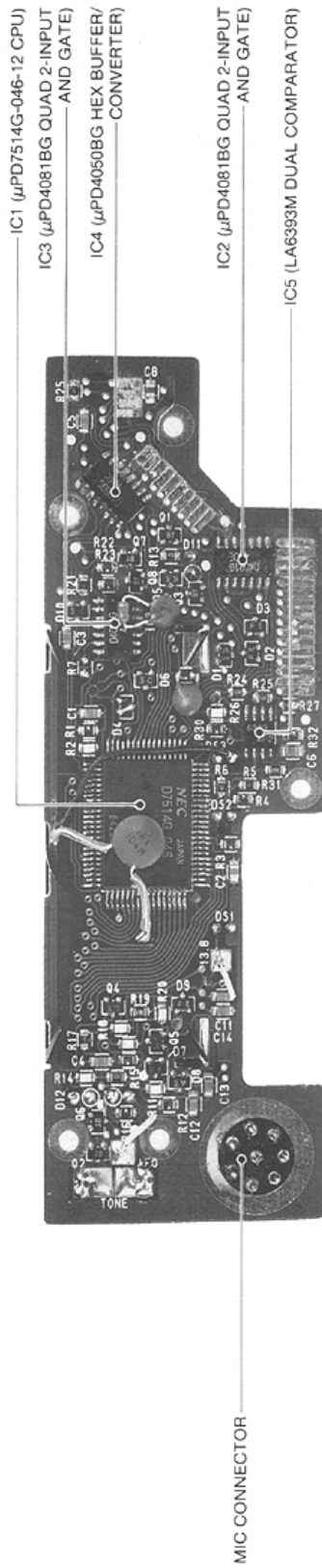

Beeps are emitted when this switch is set in the ON position. Scanning resumes immediately after a signal fades unless this switch is set in the ON position. With the switch ON scanning is delayed 5 seconds after the signal fades.
 Locks a memorized frequency, freezing the TUNING CONTROL, when the switch is set in the OFF position.
 Changes scanning speed from FAST to SLOW in scan modes. FAST [ON], SLOW [OFF].

1. BEEP ON/OFF SWITCH
2. SCAN STOP INTERVAL SWITCH
3. MEMORY DIAL LOCK SWITCH
4. SCAN SPEED SWITCH

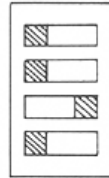

LOGIC B UNIT

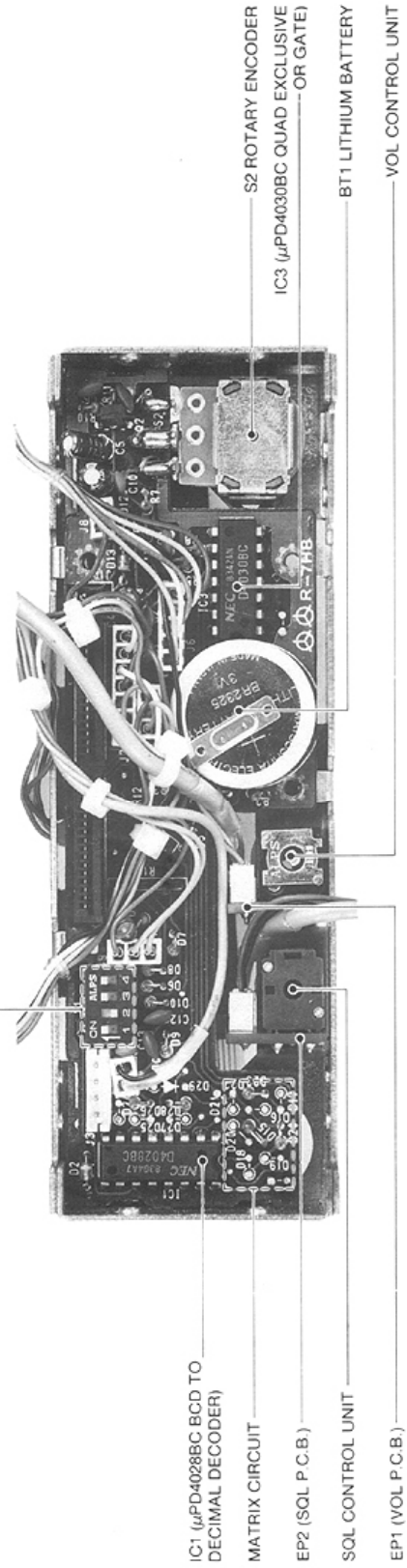

SECTION 8 DISASSEMBLY AND ASSEMBLY DIAGRAMS

8 - 1 FRAME DISASSEMBLY

1. Remove 4 screws ① from the top cover and lift the cover free.
2. Remove 4 screws ② from the bottom cover.
3. Unplug speaker plug P4 on the bottom cover and lift the cover free.
4. Remove knobs and MIC CONNECTOR RING from the front panel.
5. Remove 4 screws ③ from the front panel and lift the panel free.

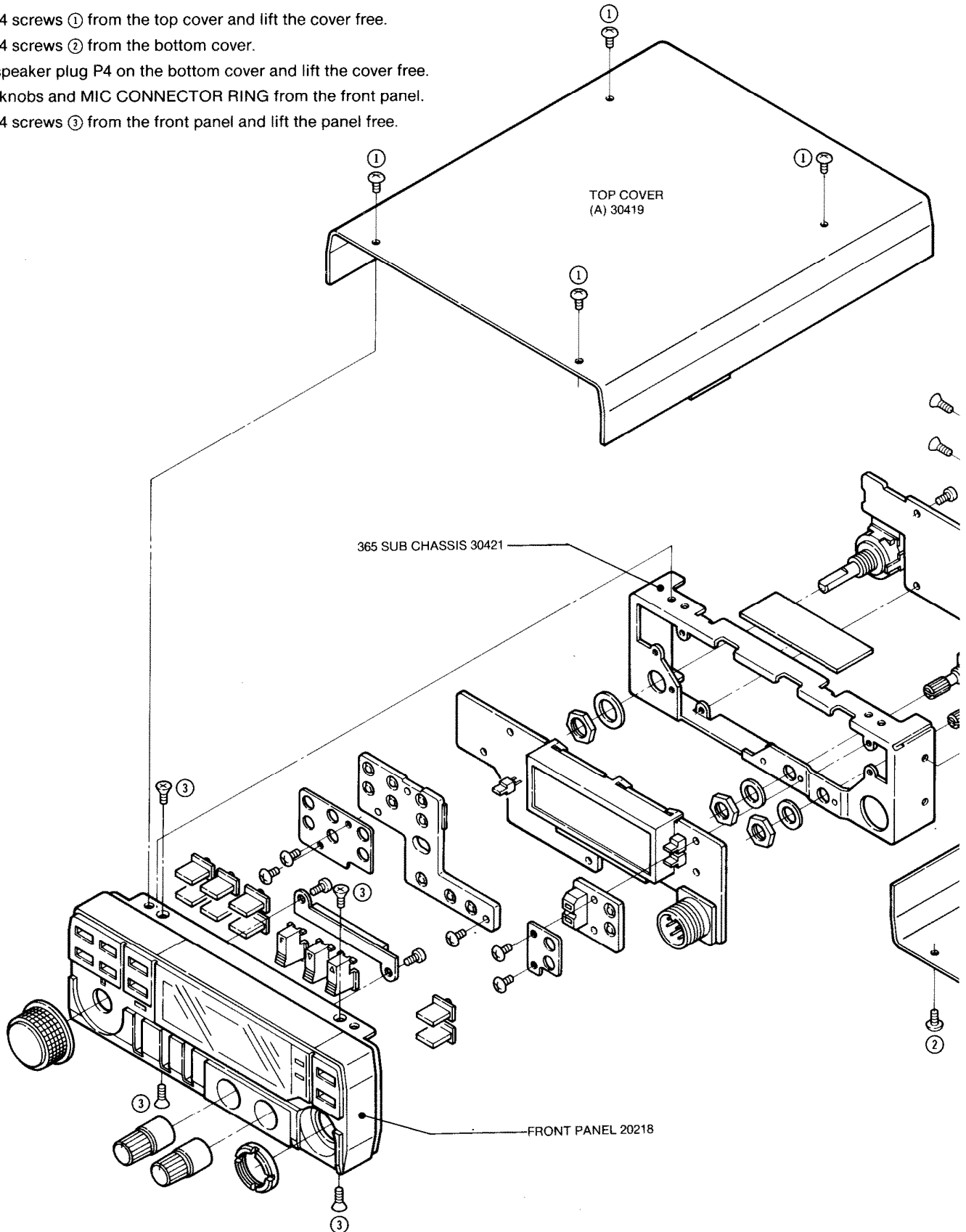

8 - 2 FRONT PANEL DISASSEMBLY

LOGIC B BOARD —
B-947D 42839

ROTARY ENCODER —
LA21613

INSULATING PLATE
(AA) 42916

365 SUB CHASSIS 30413

365 LCD HOLDER 42830

LCD HLC9235-01-200

FUNC LED SLP415B

SWITCH HOLDER 30414

FRONT SHIELD (A) 42914

SWITCH PLATE 42845

PUSH BUTTONS K-40 (A) 42821

PUSH BUTTONS K-40 42821

FUNCTION BUTTON K-41 (A) 42822

TUNING CONTROL KNOB
N-85 42844

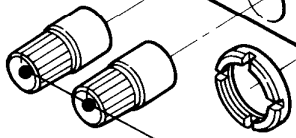
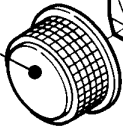

VOLUME/POWER AND
SQUELCH CONTROL KNOBS
N-84 42823

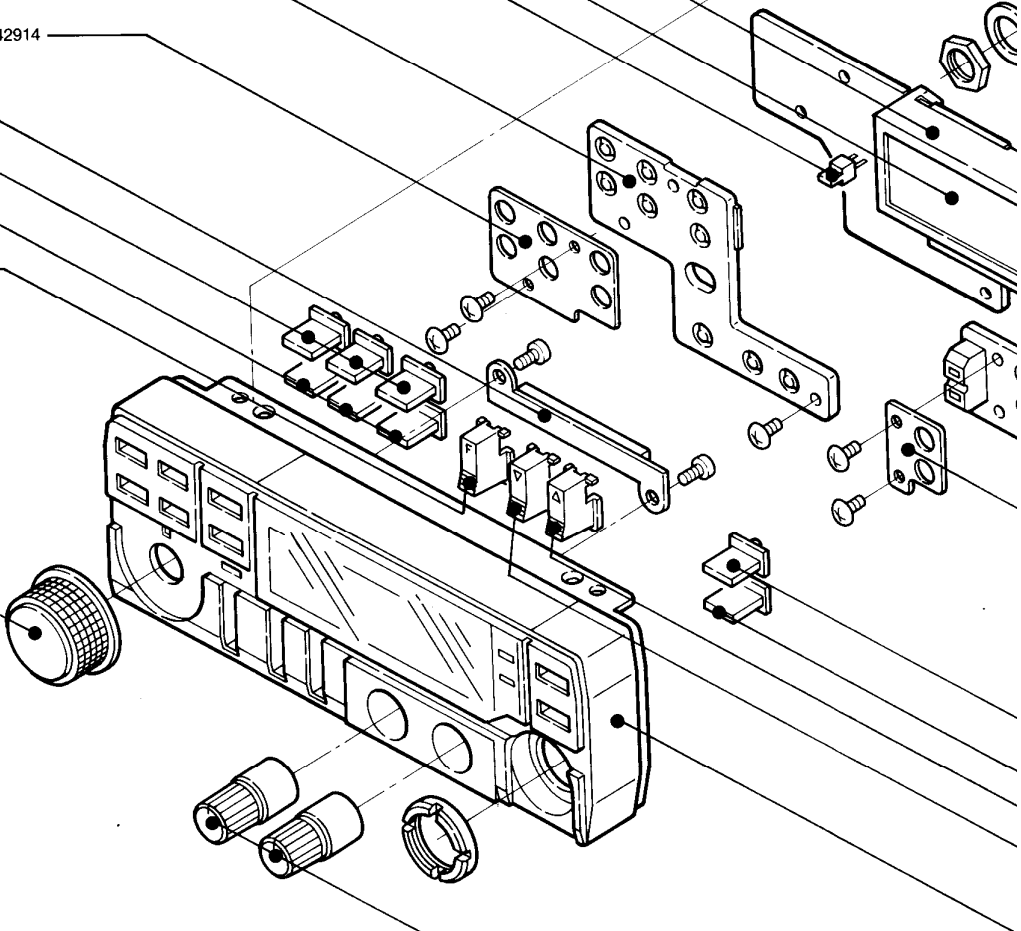

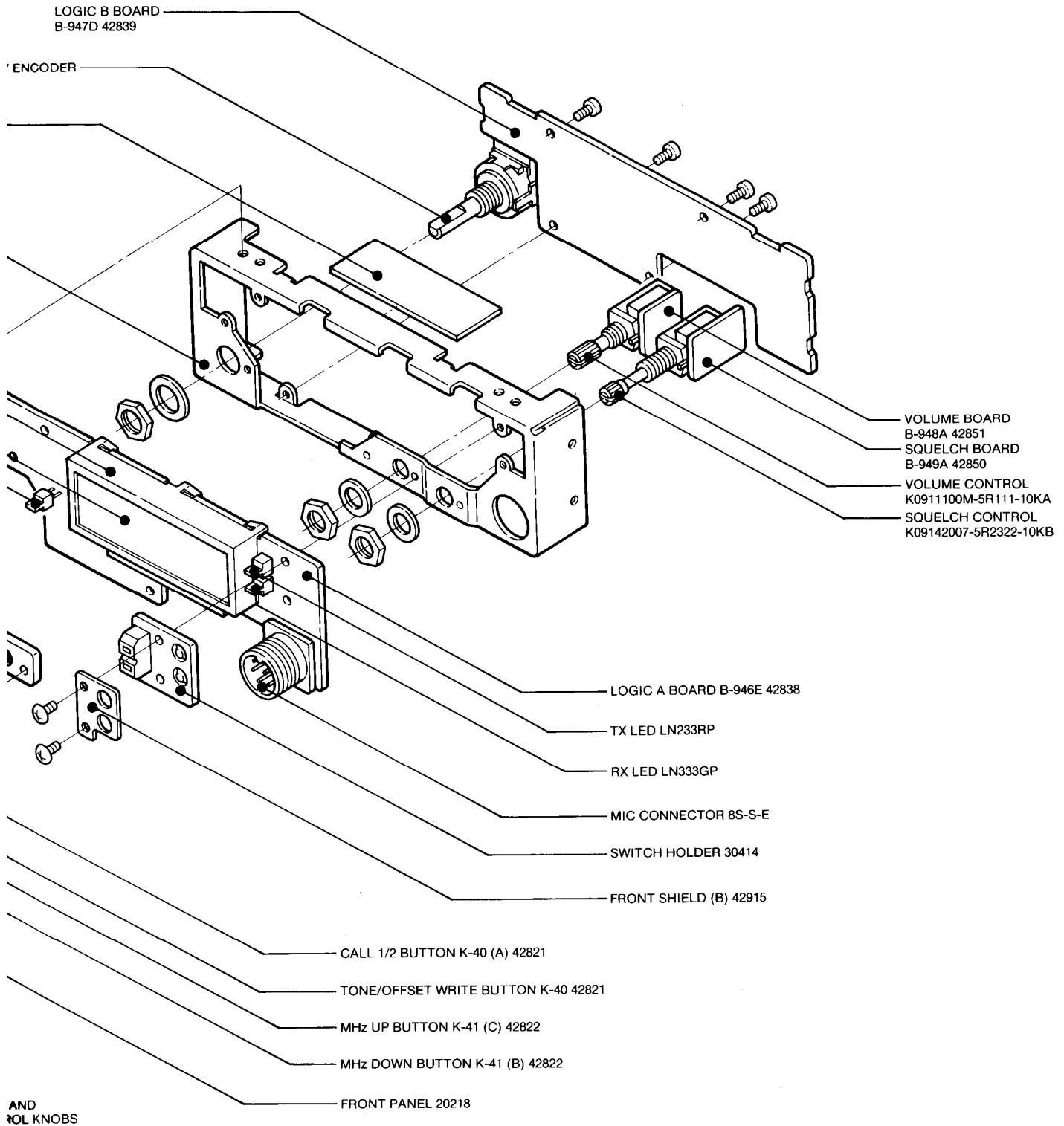

8 - 3 MAIN UNIT CONNECTOR ASSEMBLY

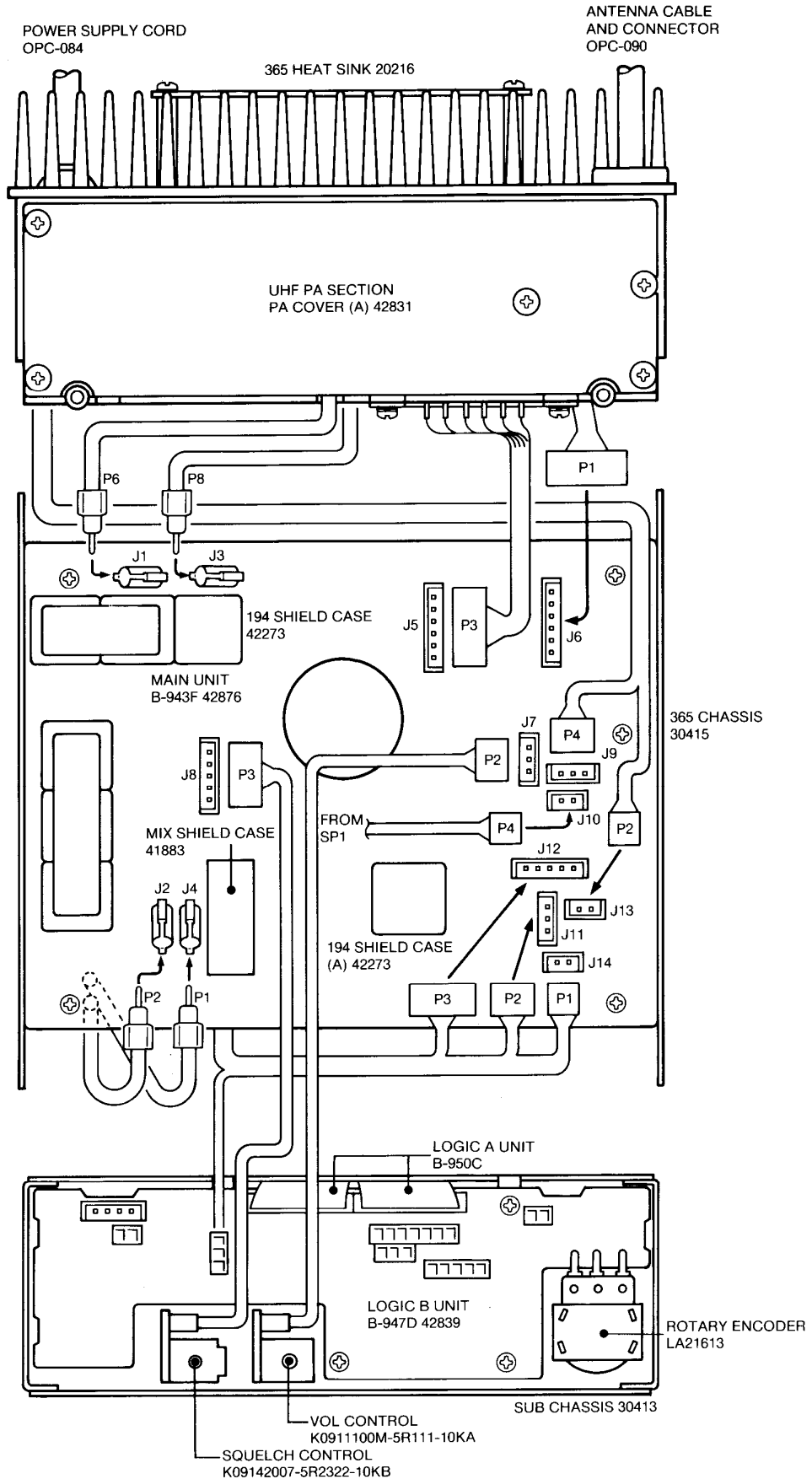

8 - 4 PLL-YGR UNIT CONNECTOR ASSEMBLY

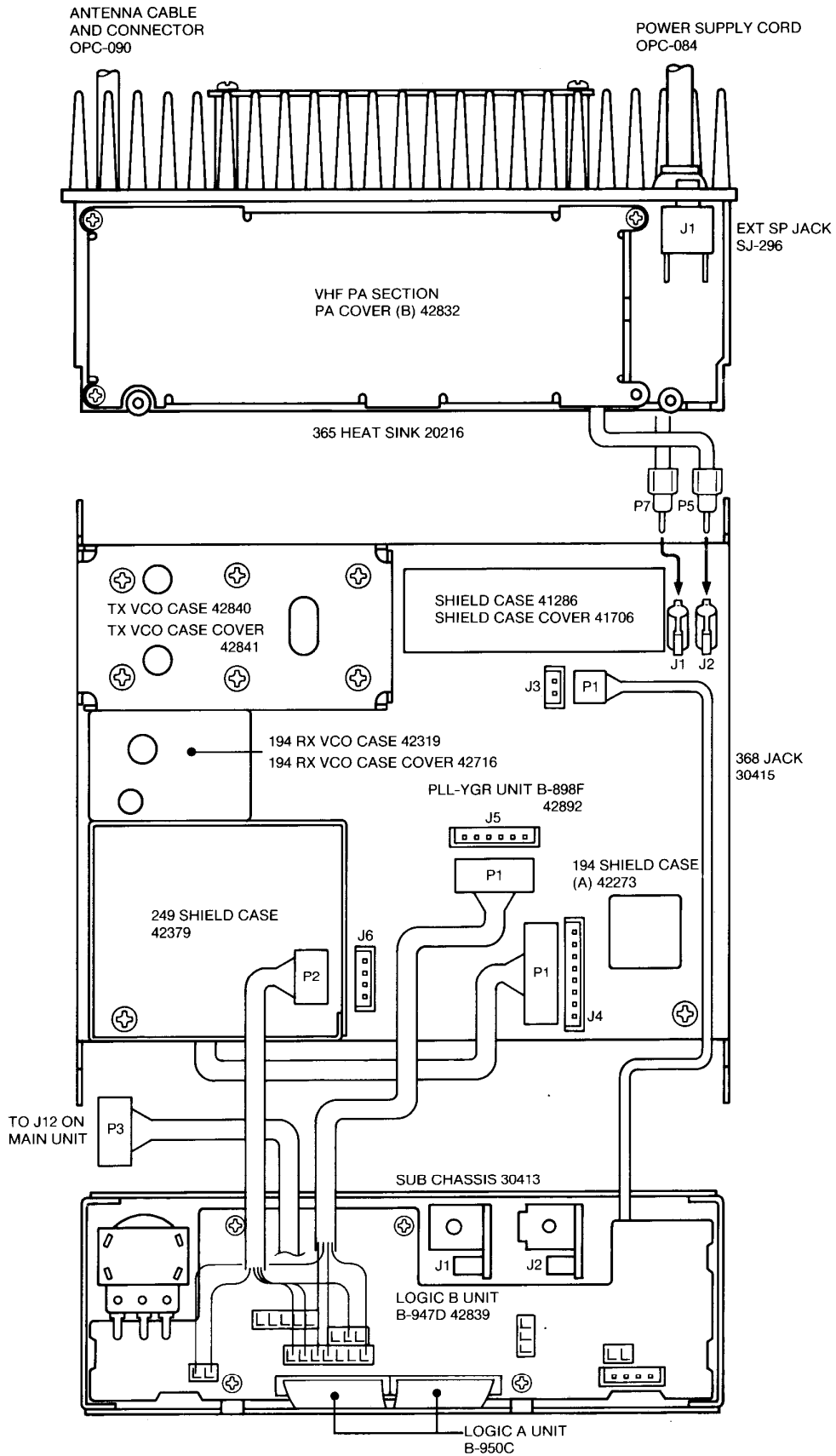

SECTION 9 BOARD LAYOUTS

9-1 MAIN UNIT

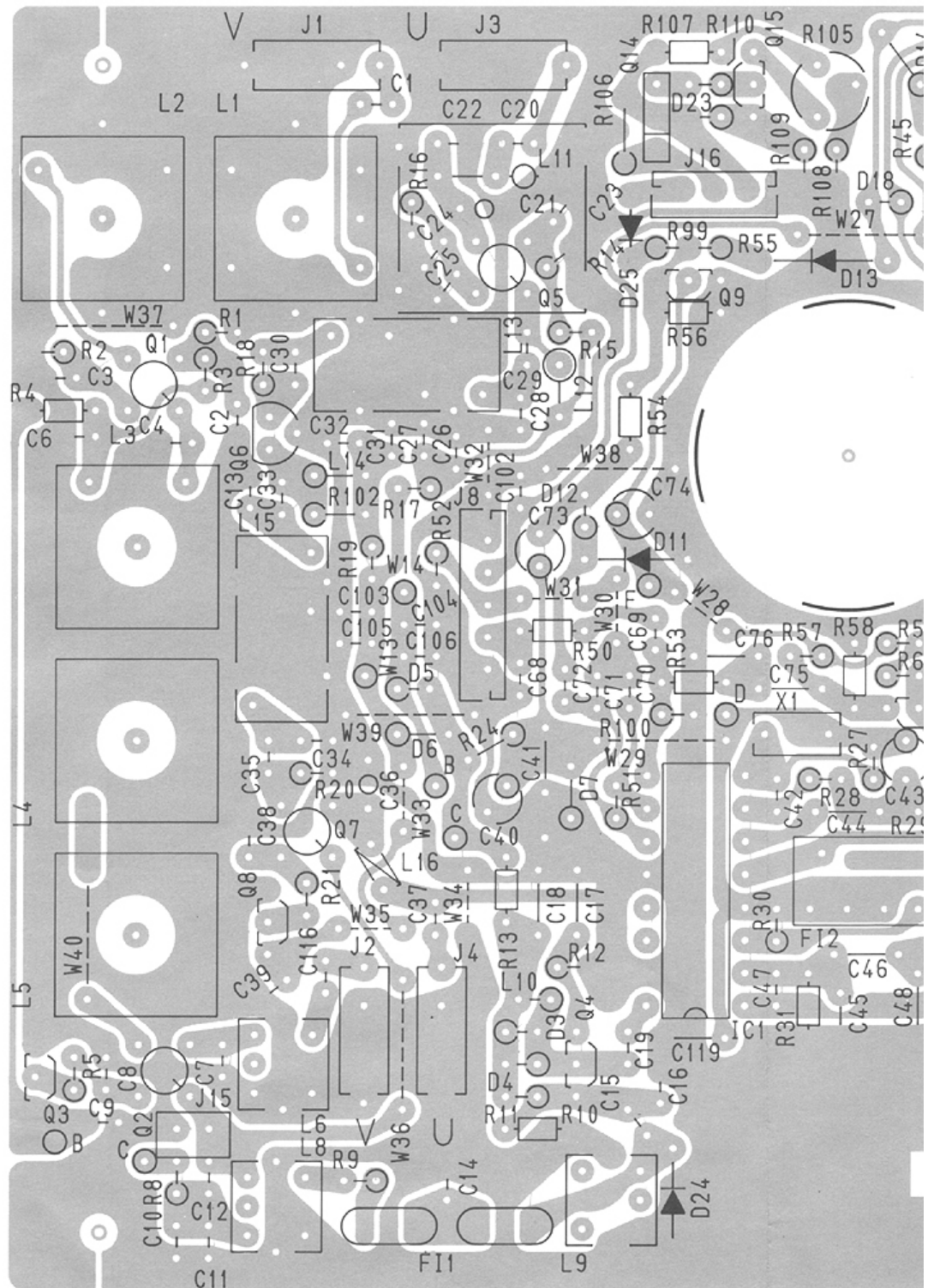

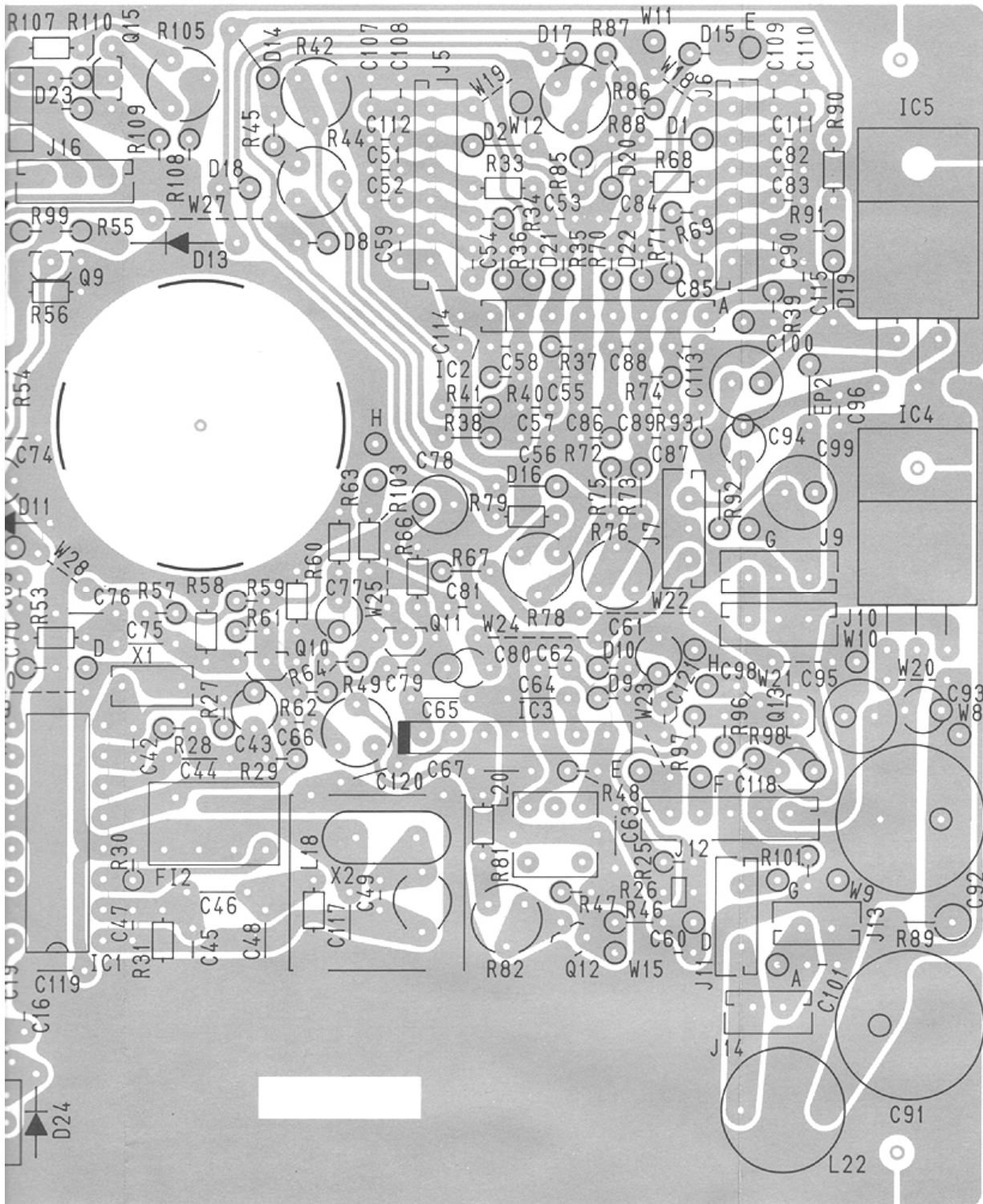

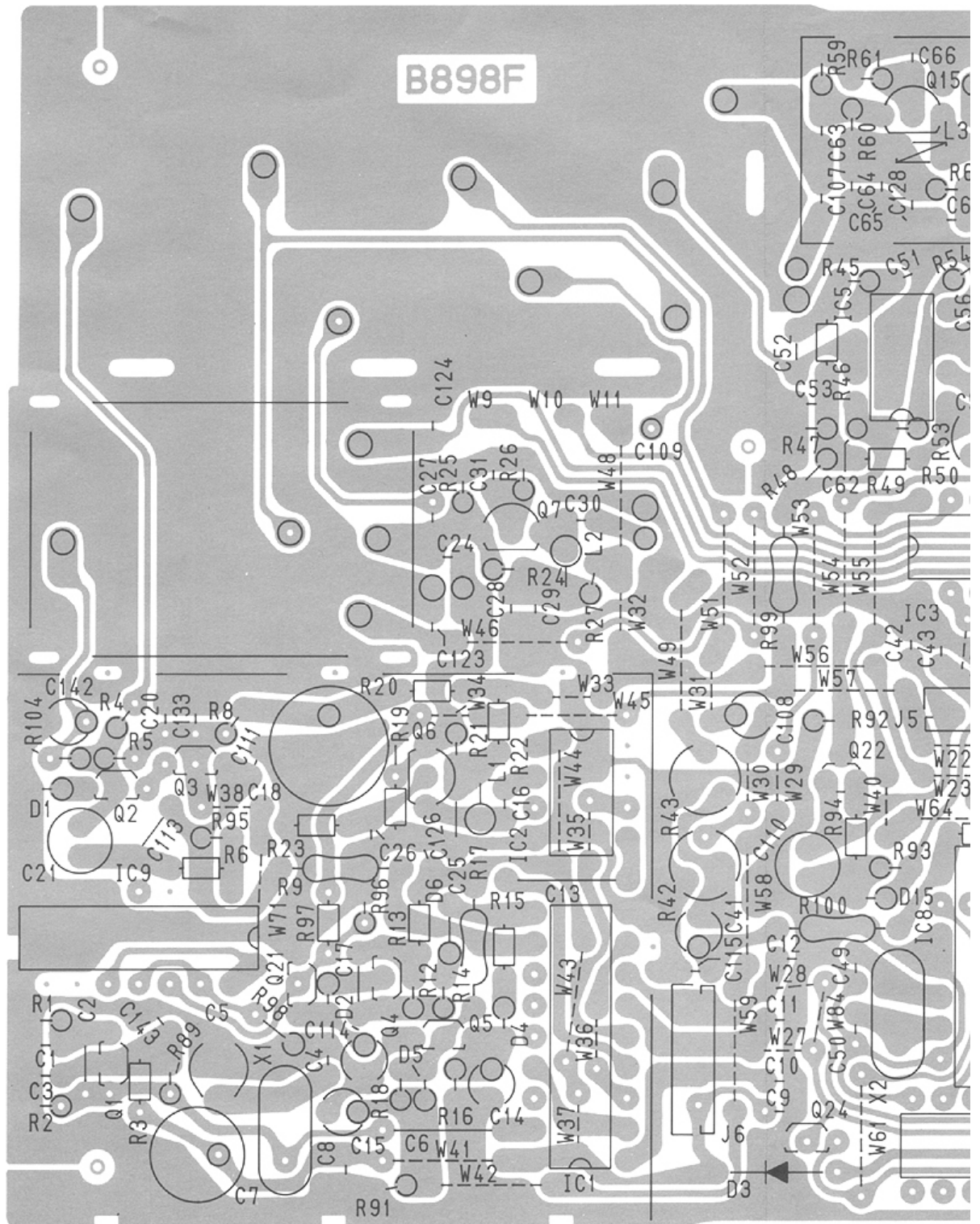

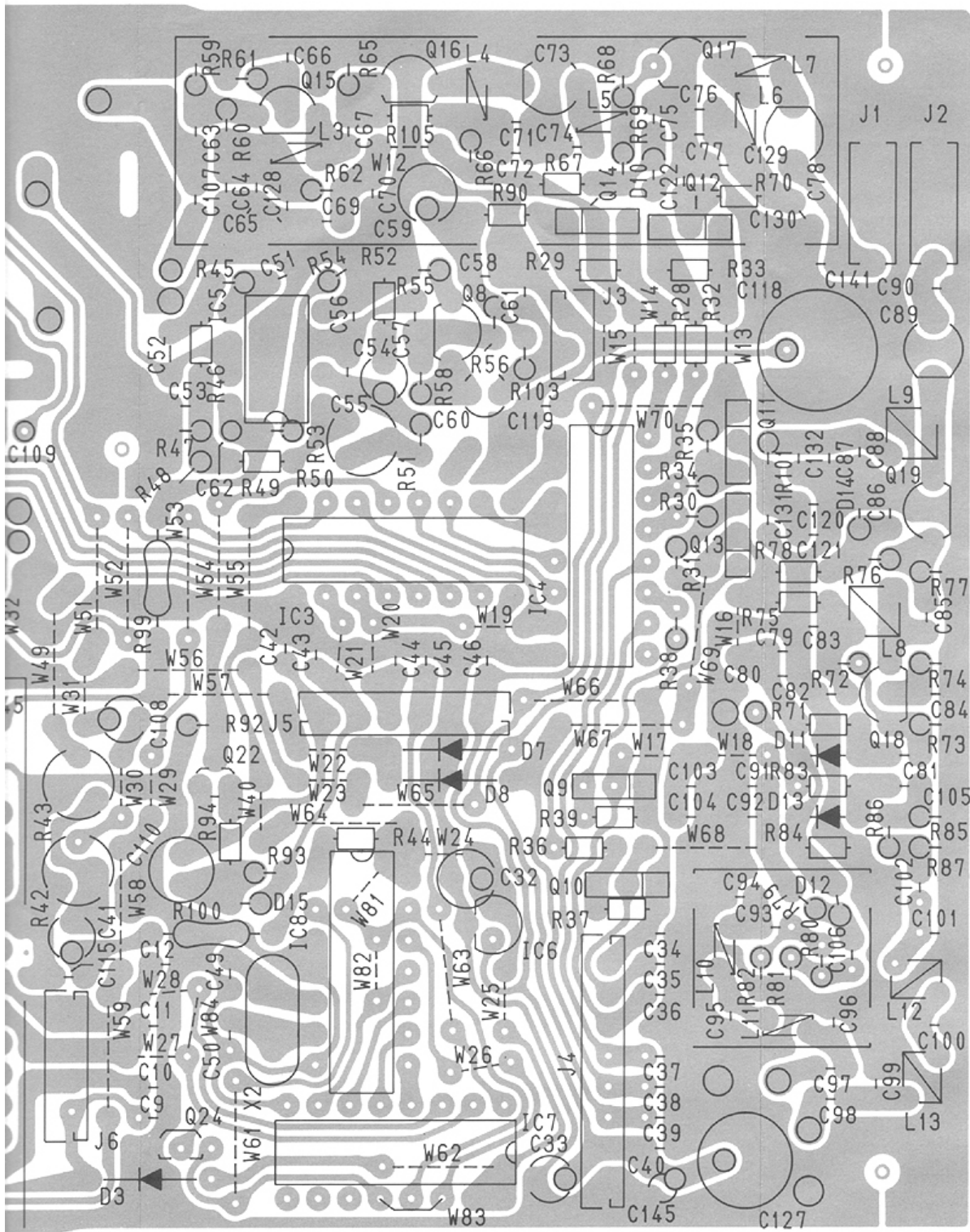

9 - 3 LOGIC A UNIT

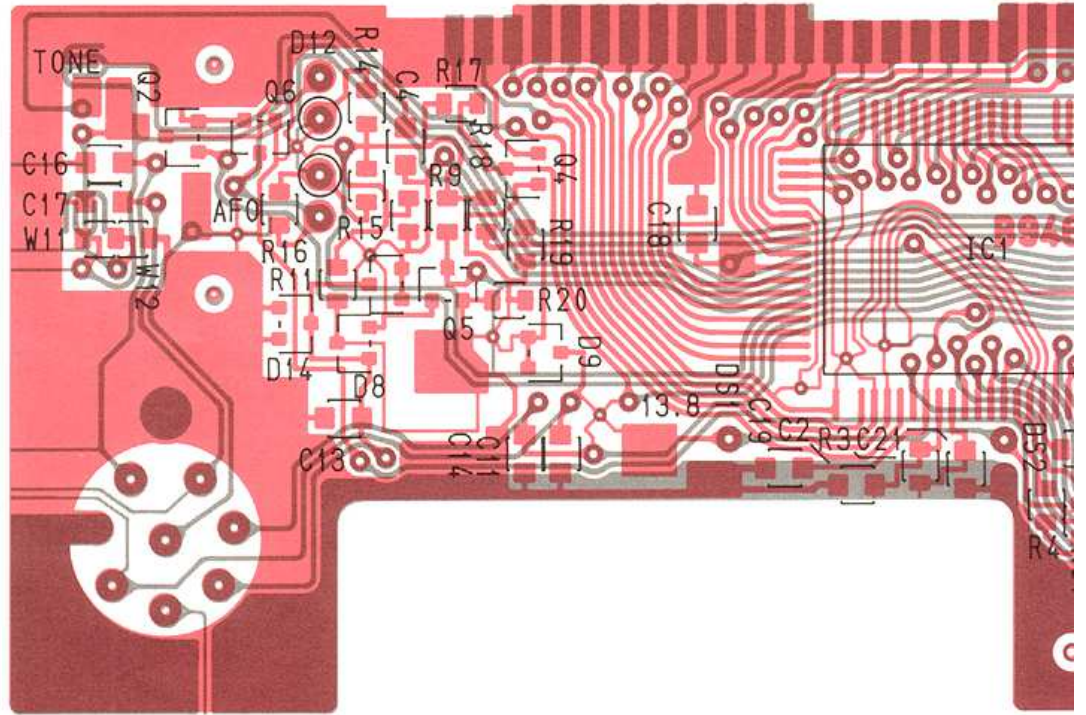

9 - 4 LOGIC B UNIT

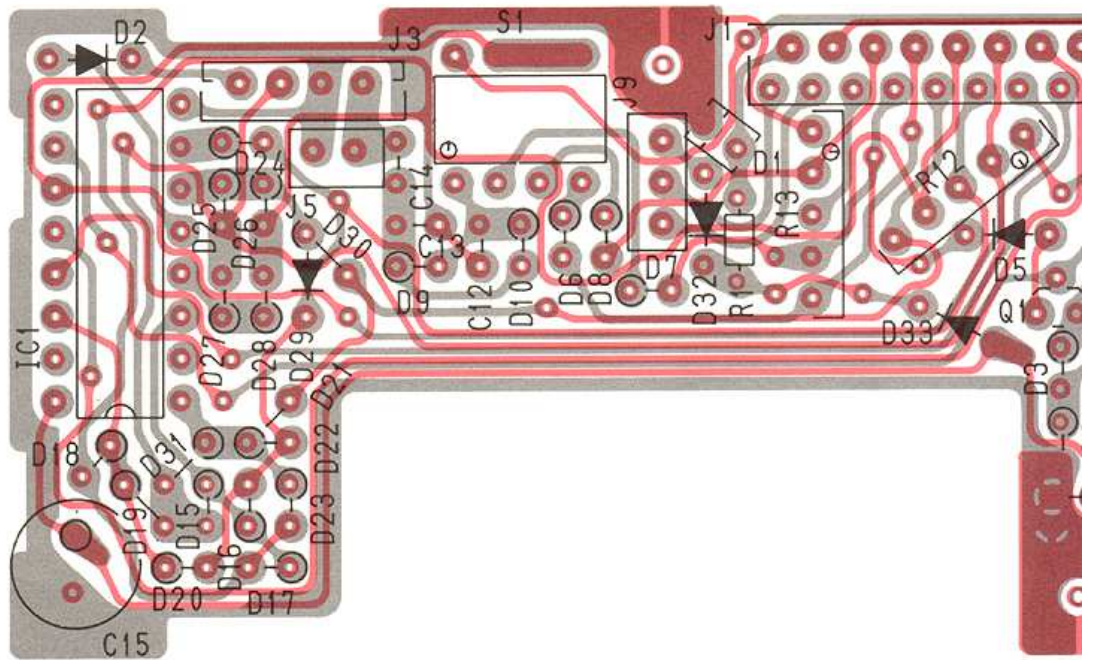

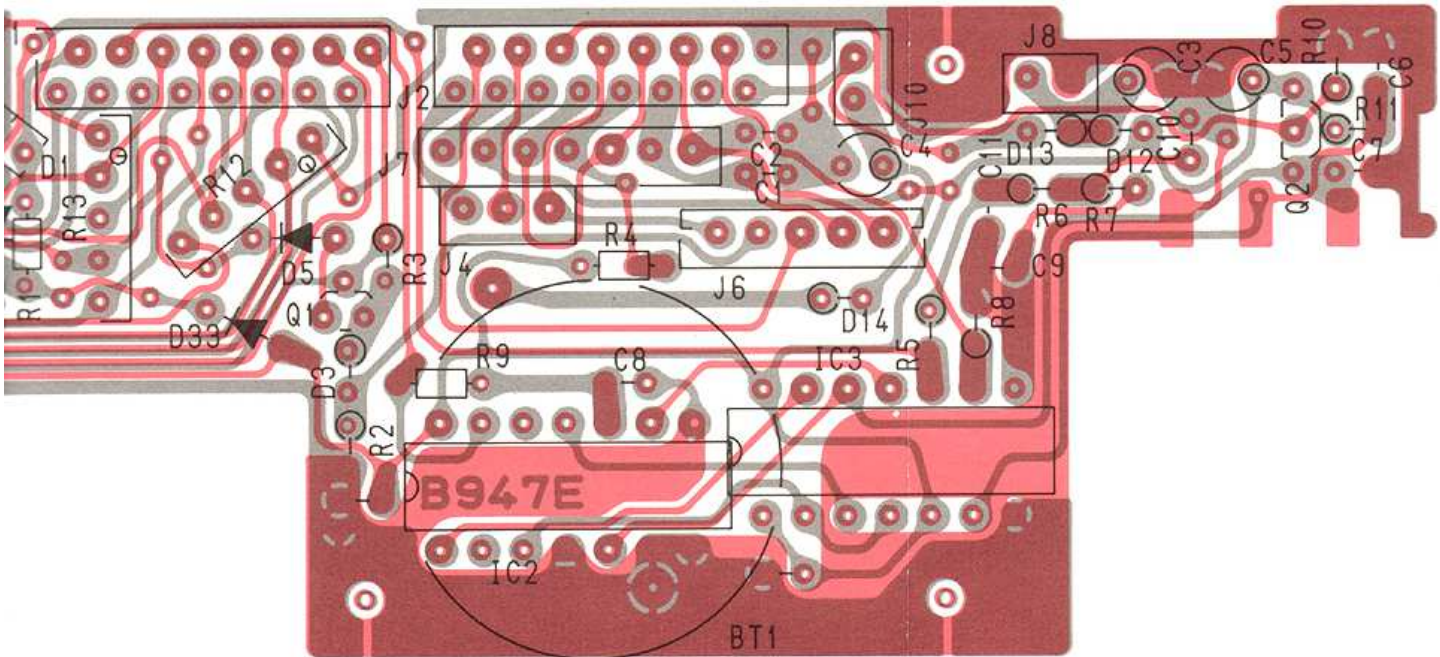
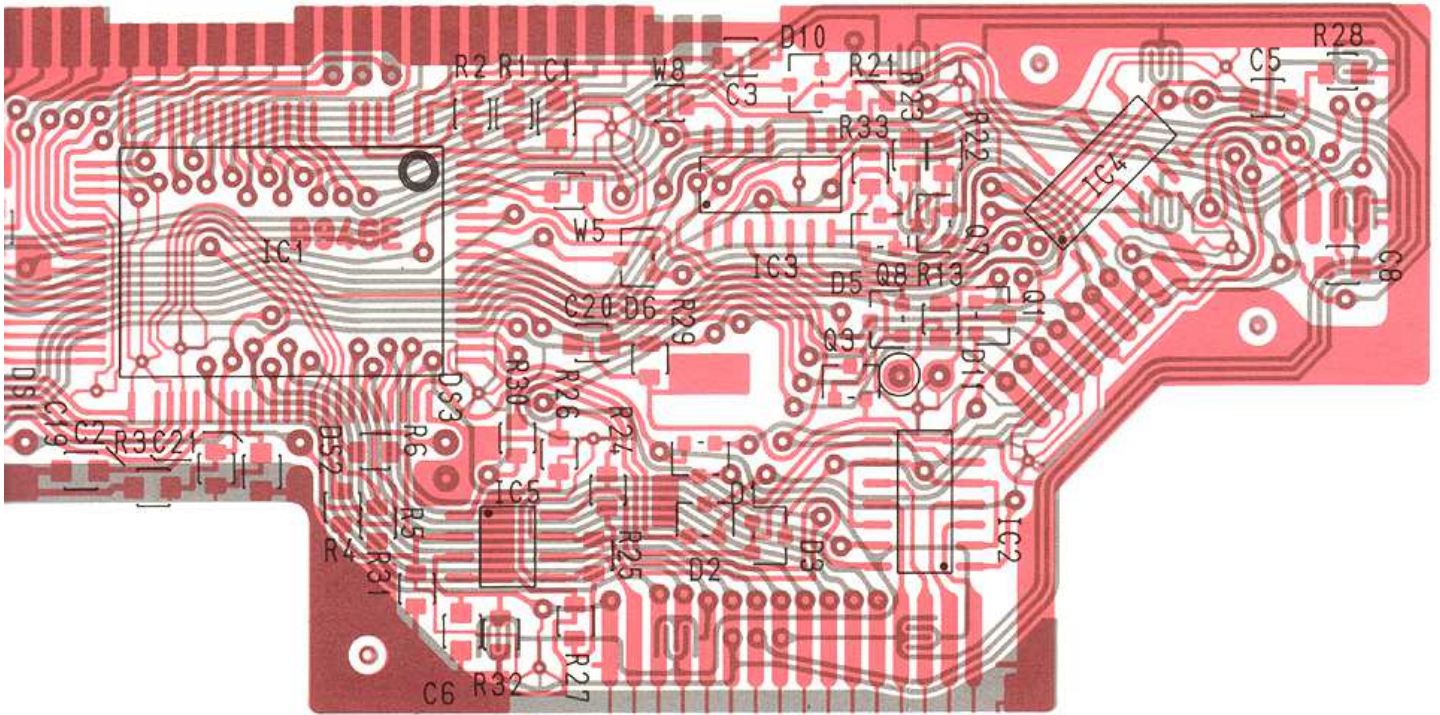

9 - 5 PA (VHF) UNIT

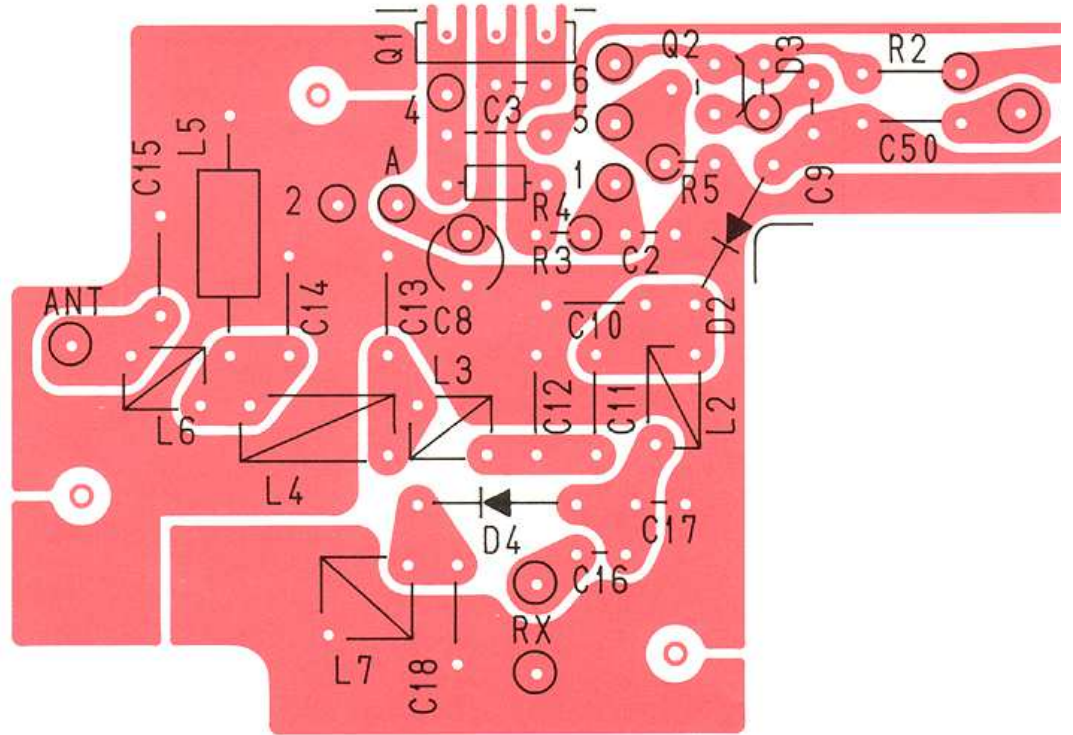

9 - 6 PA (UHF) UNIT



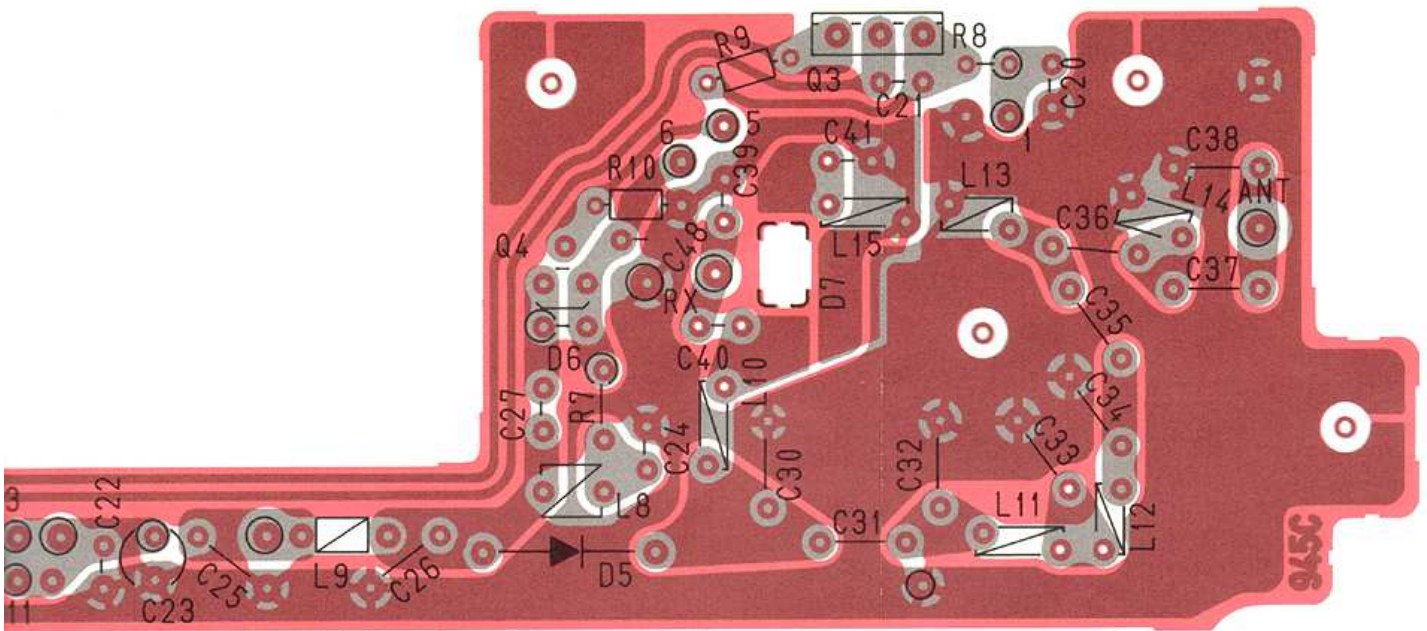
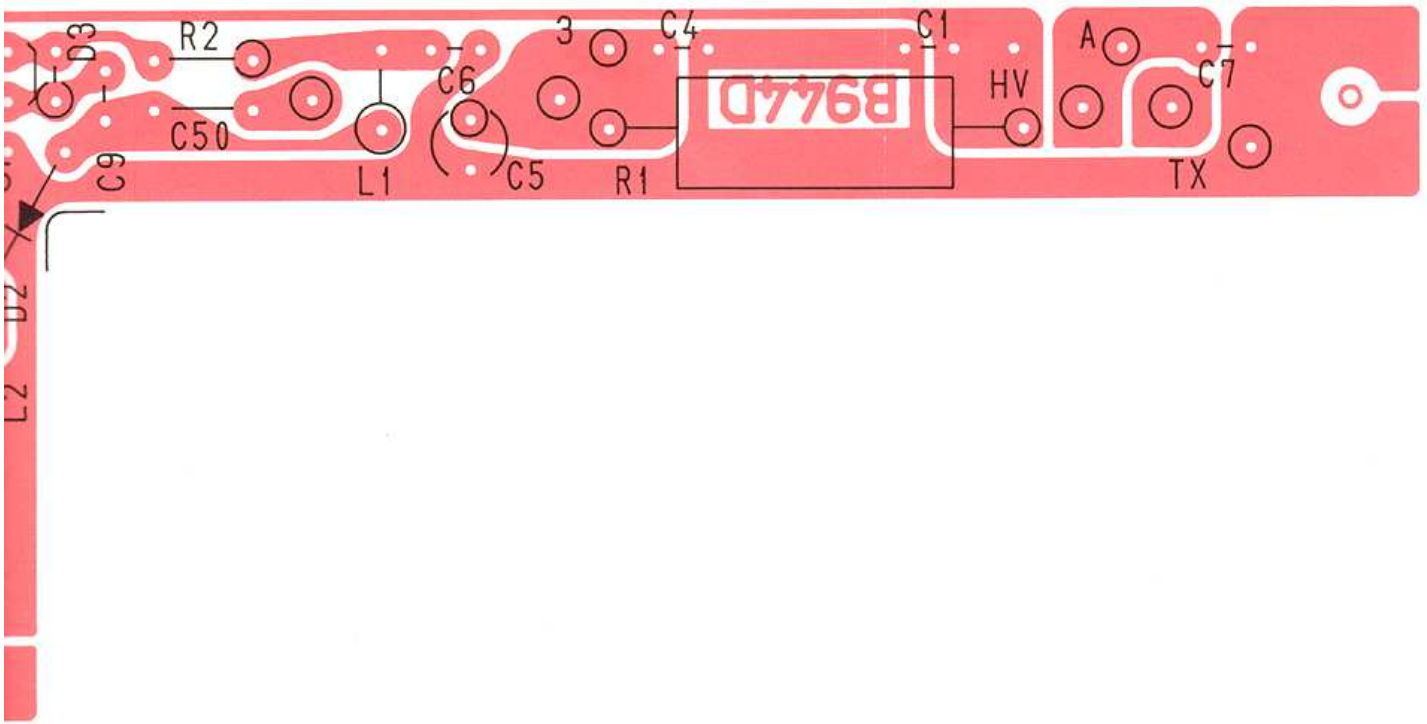

9-7 TX VCO UNIT

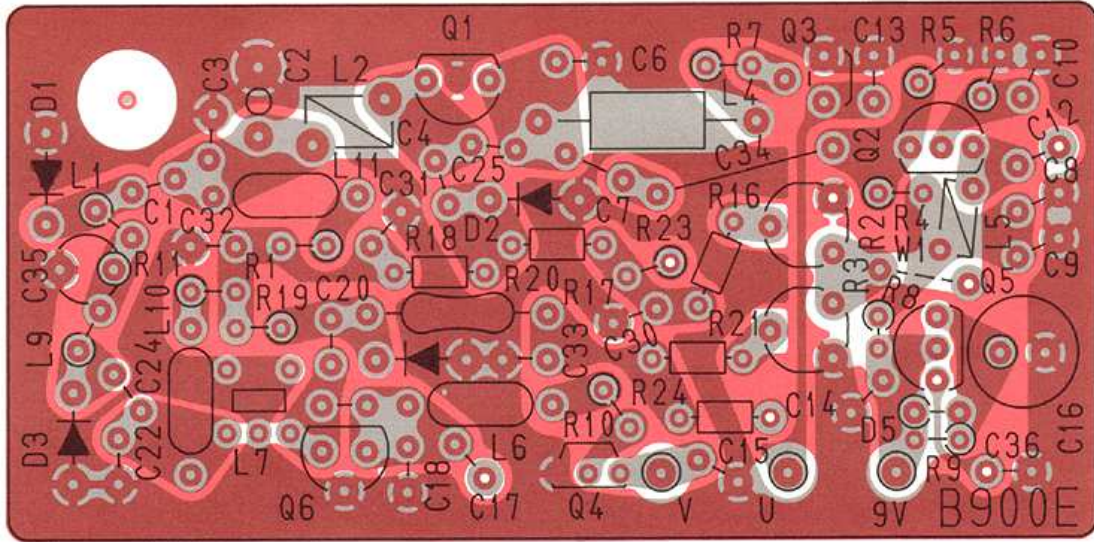

9-8 RX VCO UNIT

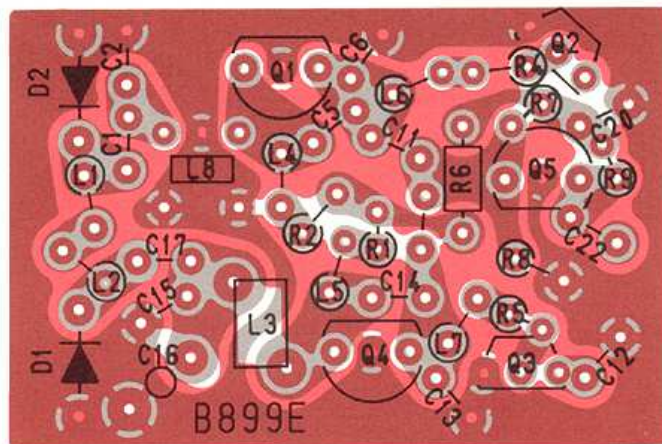

9 - 9 EF (VOL) UNIT

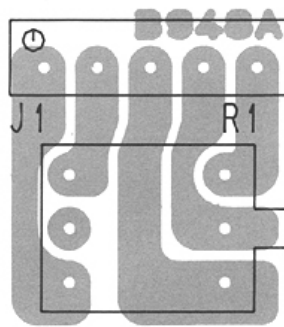

9 - 10 EF (SQL) UNIT

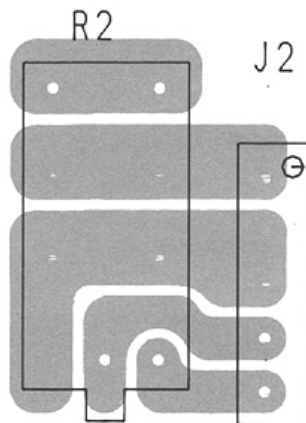

SECTION 11 IC RATINGS

μPD2834C (PLL FREQUENCY SYNTHESIZER)

MAXIMUM RATINGS (Ta = 25°C)

DESCRIPTION	SYMBOL	RATINGS	UNIT
Power supply voltage	V _{DD}	-0.3~+7.0	V
Input voltage	V _{IN}	-0.5~+V _{DD} +0.5	V
Output voltage	V _{OUT}	-0.5~+V _{DD} +0.5	V
Output voltage*	V _{OUT}	-0.5~+V _{DD} +3.0	V
Operating temperature	T _{OPR}	-40~+85	°C
Storage temperature	T _{STG}	-65~+150	°C

*EOU pin only

PIN CONNECTION (Top View)

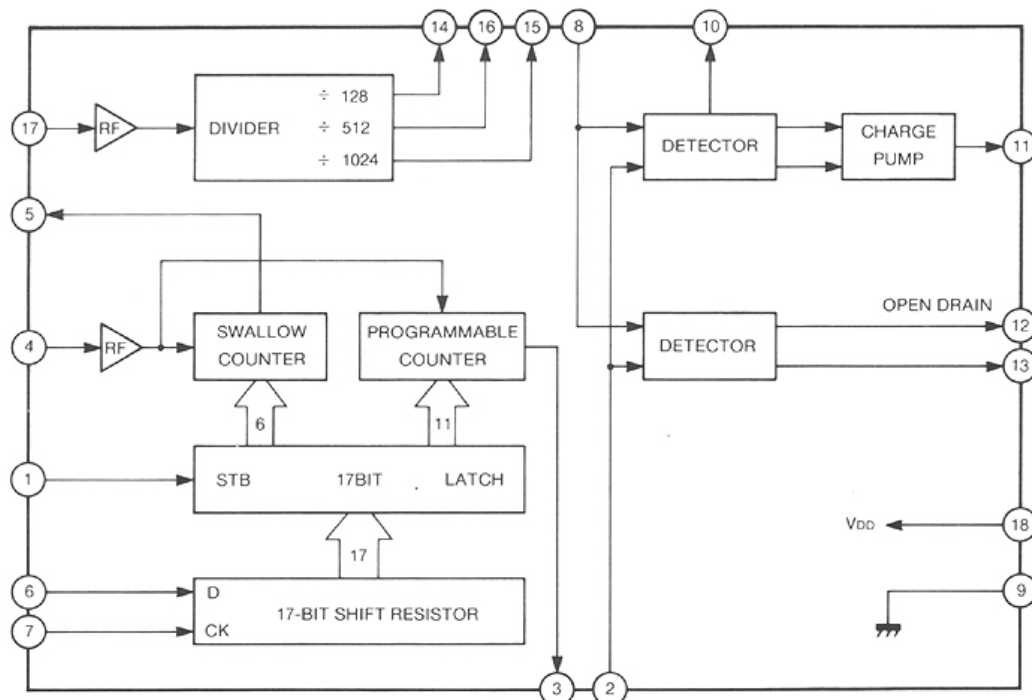
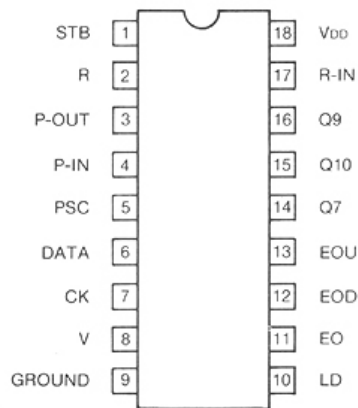

μPB571C (LOW POWER PRE-SCALER)

MAXIMUM RATINGS (Ta = 25°C)

DESCRIPTION	SYMBOL	RATINGS	UNIT
Power supply voltage	V _{CC}	-0.5~+6.0	V
Input voltage	V _{IN}	-0.5~+V _{CC} +0.5	V
Maximum drive current	I _{OUT}	-10	mA
Storage temperature	T _{STG}	-55~+125	°C

PIN CONNECTION (Top View)

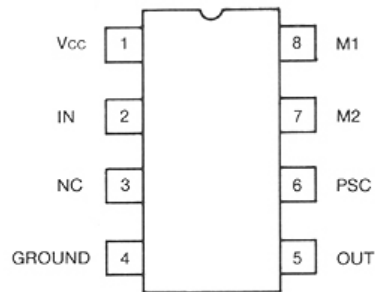

BLOCK DIAGRAM

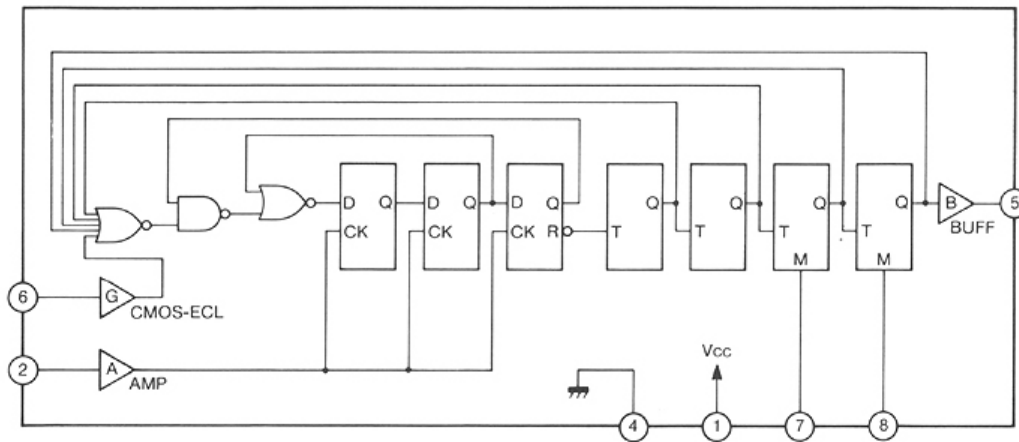

S-7116A (TONE GENERATOR CMOS LSI)

MAXIMUM RATINGS

DESCRIPTION	SYMBOL	RATINGS	UNIT
Power supply voltage	V _{DD}	12.0	V
Input voltage	V _{IN}	V _{SS} -0.3~V _{DD} +0.3	V
Output voltage	V _{OUT}	V _{SS} -0.3~V _{DD} +0.3	V
Package dissipation	P _D	300	mW
Operating temperature	T _{OPR}	-25~+70	°C
Storage temperature	T _{STG}	-40~+125	°C

PIN CONNECTION (Top View)

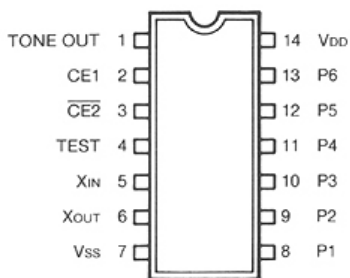

BLOCK DIAGRAM

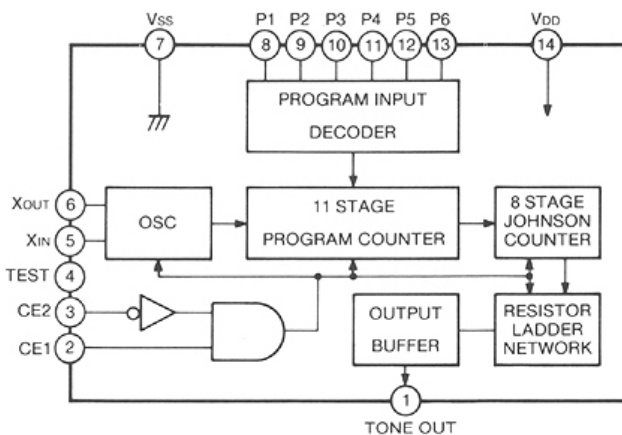

P1 ~ P6 CODE VS. TONE FREQUENCY

f_{osc} = 3.579545MHz

TONE FREQ.	P1	P2	P3	P4	P5	P6	TONE FREQ.	P1	P2	P3	P4	P5	P6	TONE FREQ.	P1	P2	P3	P4	P5	P6
67.0	1	0	0	0	0	0	131.8	0	0	1	0	1	0	500	1	1	1	0	0	1
71.9	0	1	0	0	0	0	136.5	1	0	1	0	1	0	600	0	0	0	1	0	1
74.4	1	1	0	0	0	0	141.3	0	1	1	0	1	0	700	1	0	0	1	0	1
77.0	0	0	1	0	0	0	146.2	1	1	1	0	1	0	800	0	1	0	1	0	1
79.7	1	0	1	0	0	0	151.4	0	0	0	1	1	0	900	1	1	0	1	0	1
82.5	0	1	1	0	0	0	156.7	1	0	0	1	1	0	1000	0	0	1	1	0	1
85.4	1	1	1	0	0	0	162.2	0	1	0	1	1	0	1600	1	0	1	1	0	1
88.5	0	0	0	1	0	0	167.9	1	1	0	1	1	0	1700	0	1	1	1	0	1
91.5	1	0	0	1	0	0	173.8	0	0	1	1	1	0	1750	1	1	1	1	0	1
94.8	0	1	0	1	0	0	179.9	1	0	1	1	1	0	1800	0	0	0	0	1	1
97.4	1	1	0	1	0	0	186.2	0	1	1	1	1	0	1300	1	0	0	0	1	1
100.0	0	0	1	1	0	0	192.8	1	1	1	1	1	0	2000	0	1	0	0	1	1
103.5	1	0	1	1	0	0	203.5	0	0	0	0	0	1	2200	1	1	0	0	1	1
107.2	0	1	1	1	0	0	210.7	1	0	0	0	0	1	2975	0	0	1	0	1	1
110.9	1	1	1	1	0	0	218.1	0	1	0	0	0	1	2550	1	0	1	0	1	1
114.8	0	0	0	0	1	0	225.7	1	1	0	0	0	1	2295	0	1	1	0	1	1
118.8	1	0	0	0	1	0	233.6	0	0	1	0	0	1	2125	1	1	1	0	1	1
123.0	0	1	0	0	1	0	241.8	1	0	1	0	0	1	1275	0	0	0	1	1	1
127.3	1	1	0	0	1	0	250.3	0	1	1	0	0	1	1445	1	0	0	1	1	1

1 = V_{DD} level
0 = V_{SS} level

unit: Hz

M54519P (7-UNIT 400mA DARLINGTON TRANSISTOR ARRAY)

MAXIMUM RATINGS

DESCRIPTION	SYMBOL	RATINGS	UNIT
Collector/Emitter voltage	V_{CE0}	40 *1	V
Collector voltage	I_C	400 *2	mA
Input voltage	V_{IN}	40	V
Package dissipation	P_D	1.47 *3	W
Operating temperature	T_{OPR}	-20~+75	°C
Storage temperature	T_{STG}	-55~+125	°C

*1: When the output becomes "H" *2: When the output becomes "L" *3: $T_a = 25^\circ\text{C}$

PIN CONNECTION (Top View)

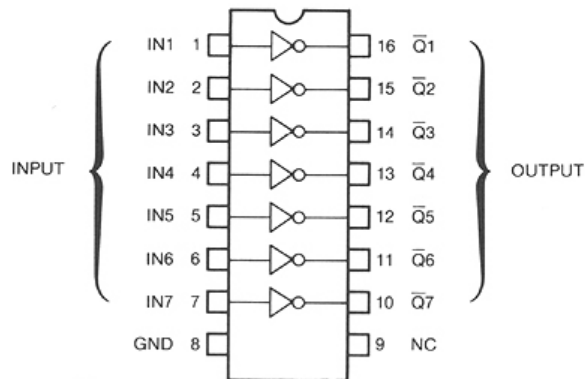

M5218L (LOW NOISE DUAL OPERATIONAL AMPLIFIER)

MAXIMUM RATINGS

DESCRIPTION	SYMBOL	RATINGS	UNIT
Power supply voltage	V_{CC}	± 18	V
Output current	I_{LP}	± 50	mA
Differential input voltage	V_{ID}	± 30	V
Input voltage	V_{IC}	± 15	V
Package dissipation	P_D	800	mW
Operating temperature	T_{OPR}	-20~+75	°C
Storage temperature	T_{STG}	-55~+125	°C

PIN CONNECTION

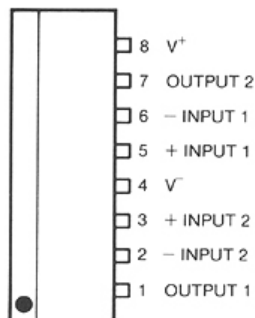

μPC577H (FM-IF AMPLIFIER)

MAXIMUM RATINGS (Ta = 25°C)

DESCRIPTION	SYMBOL	RATINGS	UNIT
Power supply voltage	V _{CC}	15	V
Input voltage	V _{IN}	±3.0	V
Package dissipation	P _D	300	mW
Operating temperature	T _{OPT}	-20 ~ +75	°C
Storage temperature	T _{STG}	-40 ~ +125	°C

PIN CONNECTION

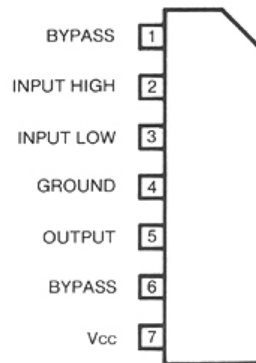

μPD4066BC (QUAD BILATERAL SWITCH)

MAXIMUM RATINGS (Ta = 25°C)

DESCRIPTION	SYMBOL	RATINGS	UNIT
Power supply voltage	V _{DD} -V _{SS}	-0.5 ~ +20	V
Input voltage	V _{IS}	-0.5 ~ V _{DD} +0.5	V
Input current	I _{IN}	10	mA
Package dissipation	P _D	200	mW
Operating temperature	T _{OPT}	-40 ~ +85	°C
Storage temperature	T _{STG}	-65 ~ +125	°C

PIN CONNECTION (Top View)

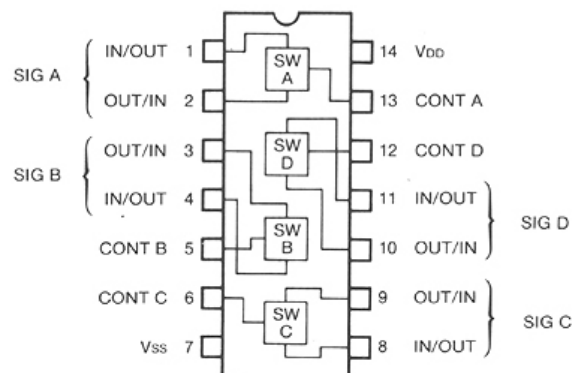

μPD4028BC (BCD TO DECIMAL DECODER)

MAXIMUM RATINGS (Ta = 25°C)

DESCRIPTION	SYMBOL	RATINGS	UNIT
Power supply voltage	V _{DD}	-0.5 ~ +20	V
Input voltage	V _{IN}	-0.5 ~ V _{DD} + 0.5	V
Input current	I _{IN}	10	mA
Package dissipation	P _D	200	mW
Operating temperature	T _{OPT}	-40 ~ +85	°C
Storage temperature	T _{STG}	-65 ~ +125	°C

PIN CONNECTION (Top View)

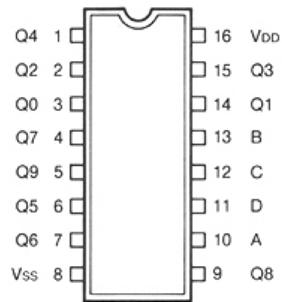

AN6541 (9V 3-TERMINAL POSITIVE VOLTAGE REGULATOR)

MAXIMUM RATINGS

DESCRIPTION	SYMBOL	RATINGS	UNIT
Power supply voltage	V _{IN}	20	V
Package dissipation	P _D	15	W
Operating temperature	T _{OPR}	-30 ~ +80	°C
Storage temperature	T _{STG}	-40 ~ +150	°C

PIN CONNECTION

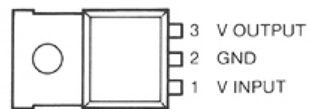

TK10420 (FM IF)

MAXIMUM RATINGS (Ta = 25°C)

DESCRIPTION	SYMBOL	RATINGS	UNIT
Power supply voltage	V _{CC}	12	V
Dissipation	P _D	540	mW
Operating voltage range	V _{OP}	4~10	V
Operating temperature	T _{OPR}	-30~+70	°C
Storage temperature	T _{STG}	-55~+125	°C

PIN CONNECTION (Top View)

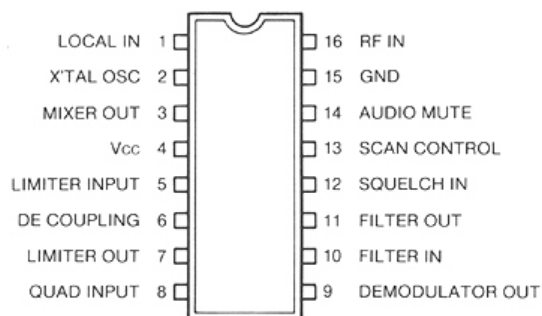

μPC2002 (5.4W AUDIO POWER AMP.)

MAXIMUM RATINGS (Ta = 25°C)

DESCRIPTION	SYMBOL	RATINGS	UNIT
Peak supply voltage	V _{CC} 1 (50ms)	40	V
DC supply voltage (quiescent)	V _{CC} 2	28	V
DC supply voltage (operational)	V _{CC} 3	18	V
Output peak current (repetitive)	I _{CC} (PEAK) 1	3.5	A
Output peak current (non-repetitive)	I _{CC} (PEAK) 2	4.5	A
Package dissipation	P _D	15*	W
Operating temperature	T _{OPR}	-30~+75	°C
Storage temperature	T _{STG}	-40~+150	°C

*T_c = 90°C

PIN CONNECTION

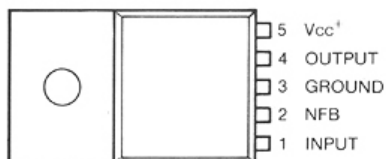

NJM4558 (DUAL LOW NOISE OPERATIONAL AMPLIFIER)

MAXIMUM RATINGS (Ta = 25°C)

DESCRIPTION	SYMBOL	RATINGS	UNIT
Power supply voltage	V _{DD}	±18	V
Input voltage	V _{IN}	±15	V
Operating temperature	T _{OPR}	-20 ~ +75	°C
Storage temperature	T _{STG}	-40 ~ +125	°C

PIN CONNECTION

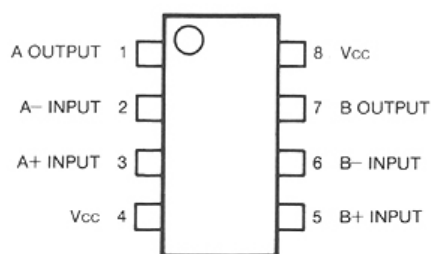

LA6393M (DUAL COMPARATOR)

MAXIMUM RATINGS

DESCRIPTION	SYMBOL	RATINGS	UNIT
Power supply voltage	V _{CC}	36	V
Differential input voltage	V _{ID}	36	V
Input voltage	V _{ICM}	-0.3 ~ +36	V
Package dissipation	P _D	300	mW
Operating temperature	T _{OPG}	-30 ~ +85	°C
Storage temperature	T _{STG}	-55 ~ +125	°C

PIN CONNECTION

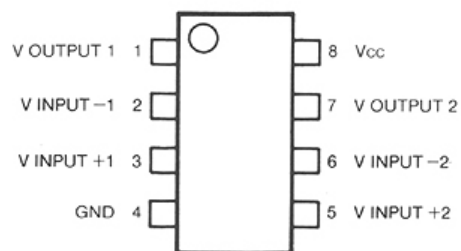

TC4555BP (DUAL BINARY TO 1-OF-4 DECODER/DEMULTIPLEXER "H"-LEVEL)

MAXIMUM RATINGS

DESCRIPTION	SYMBOL	RATINGS	UNIT
Power supply voltage	V _{DD}	V _{SS} -0.5 ~ V _{SS} +20	V
Input voltage	V _{IN}	V _{SS} -0.5 ~ V _{DD} +0.5	V
Output voltage	V _{OUT}	V _{SS} -0.5 ~ V _{DD} +0.5	V
Input current	I _{IN}	±10	mA
Package dissipation	P _D	300	mW
Storage temperature	T _{STG}	-65 ~ +150	°C

PIN CONNECTION (Top View)

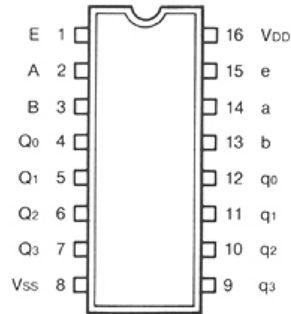

TC4094BP (8-STAGE SHIFT-AND-STORE BUS REGISTER)

MAXIMUM RATINGS

DESCRIPTION	SYMBOL	RATINGS	UNIT
Power supply voltage	V _{DD}	V _{SS} -0.5 ~ V _{SS} +20	V
Input voltage	V _{IN}	V _{SS} -0.5 ~ V _{DD} +0.5	V
Output voltage	V _{OUT}	V _{SS} -0.5 ~ V _{DD} +0.5	V
Input current	I _{IN}	±10	mA
Package dissipation	P _D	300	mW
Storage temperature	T _{STG}	-65 ~ +150	°C

PIN CONNECTION (Top View)

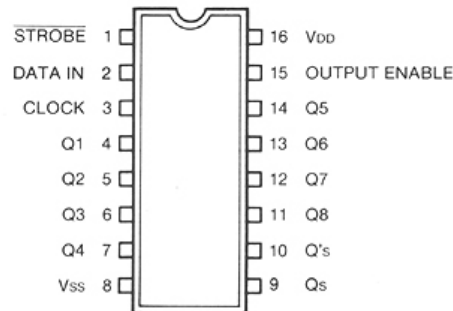

μPD4013BC (DUAL D-TYPE FLIP-FLOP)

MAXIMUM RATINGS (Ta = 25°C)

DESCRIPTION	SYMBOL	RATINGS	UNIT
Power supply voltage	V _{DD}	-0.5 ~ +20	V
Input voltage	V _{IN}	-0.5 ~ V _{DD} + 0.5	V
Input current	I _{IN}	10	mA
Package dissipation	P _D	200	mW
Operating temperature	T _{OPT}	-40 ~ +85	°C
Storage temperature	T _{STG}	-65 ~ +125	°C

PIN CONNECTION (Top View)

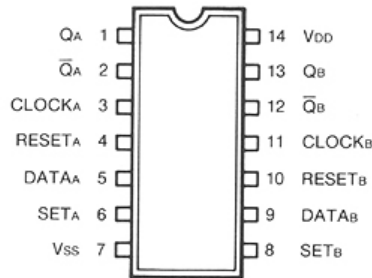

μPD4030BC (QUAD EXCLUSIVE OR GATE)

MAXIMUM RATINGS (Ta = 25°C)

DESCRIPTION	SYMBOL	RATINGS	UNIT
Power supply voltage	V _{DD}	-0.5 ~ +20	V
Input voltage	V _{IN}	-0.5 ~ V _{DD} + 0.5	V
Input current	I _{IN}	10	mA
Package dissipation	P _D	200	mW
Operating temperature	T _{OPT}	-40 ~ +85	°C
Storage temperature	T _{STG}	-65 ~ +125	°C

PIN CONNECTION (Top View)

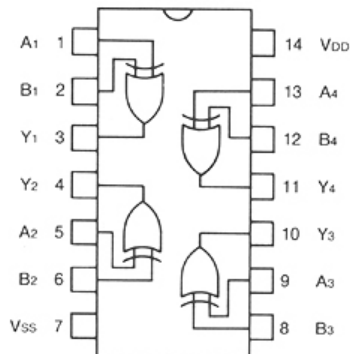

μPD4050BG (HEX. BUFFER/CONVERTER)

MAXIMUM RATINGS (Ta = 25°C)

DESCRIPTION	SYMBOL	RATINGS	UNIT
Power supply voltage	V _{DD}	-0.5 ~ +20	V
Input voltage	V _{IN}	-0.5 ~ +20	V
Input current	I _{IN}	10	mA
Maximum drive current	I _{OUT}	45	mA
Package dissipation	P _D	200	mW
Operating temperature	T _{OPT}	-40 ~ +85	°C
Storage temperature	T _{STG}	-65 ~ +125	°C

PIN CONNECTION (Top View)

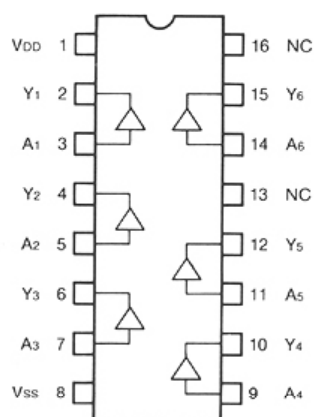

μPD4081BG (QUAD 2-INPUT AND GATE)

MAXIMUM RATINGS (Ta = 25°C)

DESCRIPTION	SYMBOL	RATINGS	UNIT
Power supply voltage	V _{DD}	-0.5 ~ +20	V
Input voltage	V _{IN}	-0.5 ~ V _{DD} +0.5	V
Input current	I _{IN}	10	mA
Package dissipation	P _D	200	mW
Operating temperature	T _{OPT}	-40 ~ +85	°C
Storage temperature	T _{STG}	-65 ~ +125	°C

PIN CONNECTION (Top View)

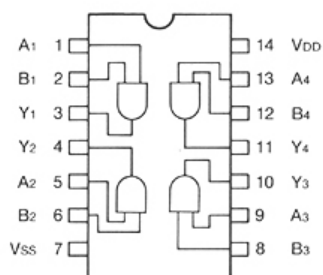

SECTION 12 OPTIONAL UNITS

Part of the tremendous versatility in the IC-3200A/E is its adaptability to base station use when not being used as a mobile unit.

The following recommended options will help complement your new base station system.

PS-45 AC POWER SUPPLY

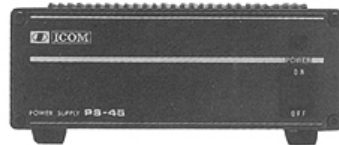

The **OPC-102 INTERFACE CABLE** for connecting the PS-45 to the IC-3200A/E must be purchased separately.

SM-10 COMPRESSOR/GRAPHIC DESK MICROPHONE



SM-8 DESK
MICROPHONE

SP-10 EXTERNAL SPEAKER



AND FOR MOBILE USE:

AH-32 DUAL BAND MOBILE ANTENNA

The AH-32 (not pictured here) is a specially designed whip antenna for mobile operation with VHF and UHF dual band transceivers. When used with the IC-3200A/E, the AH-32 requires only one feed line and no special duplexer for feeding RF signals into the antenna element.

HS-15 MOBILE FLEXIBLE MICROPHONE

- Uni-directional mic
- Flexible neck
- Connecting cable to HS-15SB SWITCHBOX
- Simple, light for driving ease.



HS-15SB SWITCHBOX



SP-8 EXTERNAL MOBILE SPEAKER



AH-7000 SUPER WIDEBAND OMNIDIRECTIONAL ANTENNA

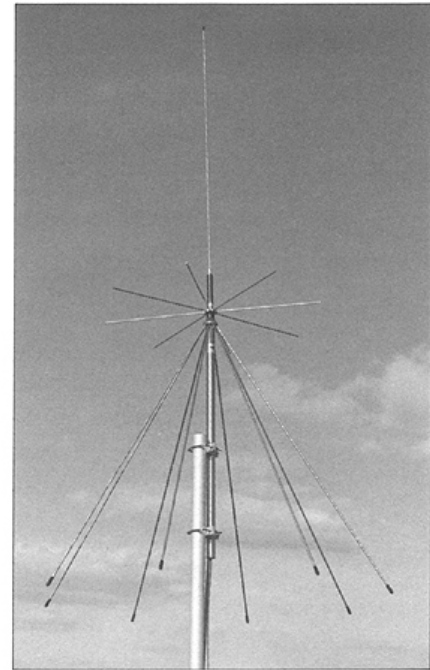

• SPECIFICATIONS

Frequency coverage: Receive 25 to 1300MHz
Transmit 50, 144, 430,
900, 1200MHz
bands

NOTE: The antenna connector supplied with the AH-7000 is a Type-N connector. This connector must be changed when using the AH-7000 with the IC-3200A/E. See your ICOM dealer for connector information.

UT-23 VOICE SYNTHESIZER UNIT

See page
12-2 for
installation
instructions.

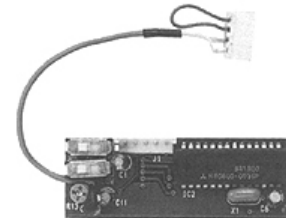

OPTIONAL UT-23 VOICE SYNTHESIZER UNIT

The optional UT-23 VOICE SYNTHESIZER UNIT can be used with the IC-3200A/E. Via an internal, electronically-generated voice, the UT-23 provides immediate operating frequency identification each time a new frequency is selected.

Carefully follow the installation instructions below before installing the UT-23.

INSTALLATION PROCEDURE

NOTE: Remove power cable before beginning installation.

1. Unscrew the four top screws and remove the top cover.
2. Unscrew the four bottom screws and remove the bottom cover.

CAUTION: The speaker is mounted inside the bottom cover. Unplug the speaker plug from the circuit board as the bottom cover is removed.

3. Remove the protective paper from the back of the UT-23 to expose the adhesive strip, and install the unit in the location shown in the bottom view of the transceiver.

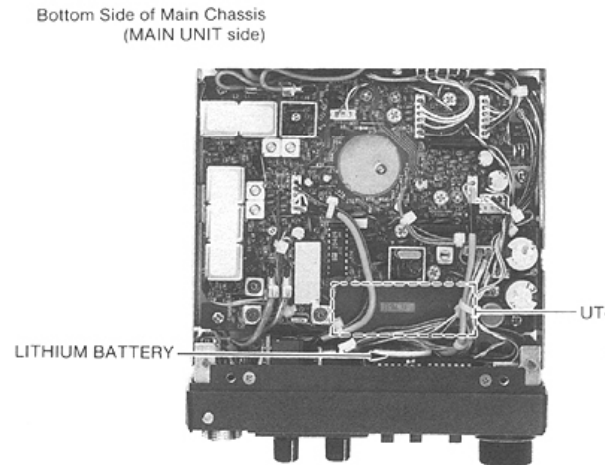

4. Insert the 5-pin plug (P7) from the transceiver into the connector (J1) mounted on the UT-23.

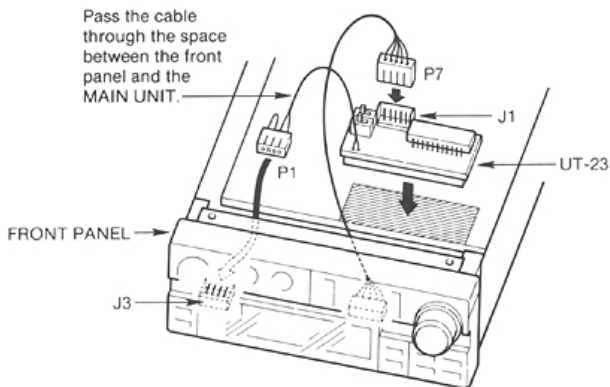

5. Insert the 4-pin plug (P1) from the UT-23 into the connector (J3) mounted on the LOGIC B UNIT.
6. Reset the transceiver CPU by the following method:
 - a) Press and hold the FUNCTION (F) SWITCH on the front panel.
 - b) Turn on the transceiver.
 - c) Release the FUNCTION (F) SWITCH, and push the switch again to turn out the FUNCTION INDICATOR.
7. The UT-23 is now installed and ready for use.

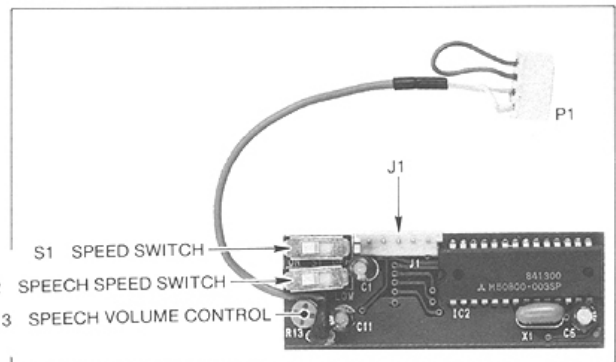

OPERATION

1. There are three controls mounted on the UT-23. They are:
 - a) SPEECH SWITCH (ON/OFF) S1
 - b) SPEECH SPEED SWITCH (HIGH/LOW) S2
 - c) SPEECH VOLUME CONTROL R13
2. Slide S1 to the ON position.
3. Slide S2 to the HIGH position for rapid speech or to the LOW position for slower speech.
4. Turn on the transceiver.
5. Operate the voice synthesizer by changing the receive frequency of the transceiver. The UT-23 automatically announces the new frequency as in the example below:

Announcement	Transceiver Display
"One Four Five Point Six Eight"	

6. Adjust R13 for a suitable speech level for your surroundings. The front panel VOLUME CONTROL also varies the voice synthesizer level.

SECTION 13 PARTS LIST

EF (VOL AND SQL) UNITS

REF. NO.	DESCRIPTION	TYPE (PART NO.)
R1	Variable	K0911100M-5R1111-10KA
R2	Variable	K09142007-5R2322-10KB
J1	Connector	TLB-P05H-B1
J2	Connector	TLB-P05H-B1
P1	Connector	EHR-02
P2	Connector	EHR-03
P3	Connector	EHR-05
P4	Connector	EHR-03
SP1	Speaker	C060A20A0000
EP1	VOL P.C.B	B-948A
EP2	SQL P.C.B	B-949A

MAIN UNIT

REF. NO.	DESCRIPTION	TYPE (PART NO.)
IC1	IC	TK10420
IC2	IC	M5218L
IC3	IC	μPC577H
IC4	IC	AN6541
IC5	IC	μPC2002H
Q1	FET	3SK121-Y
Q2	FET	3SK121-Y
Q3	Transistor	2SC3399
Q4	Transistor	2SC2668-O
Q5	FET	3SK121-Y
Q6	FET	2SK125
Q7	FET	3SK97-Q2
Q8	Transistor	2SC3399
Q9	Transistor	2SC2458-GR
Q10	Transistor	2SC2458-GR
Q11	Transistor	2SC2458-GR
Q12	Transistor	2SC3399
Q13	Transistor	2SC2458-GR
Q14	Transistor	2SB909-MR
Q15	Transistor	2SC2458-GR
D1	Diode	1SS53
D2	Diode	1SS53
D3	Diode	1SS53
D4	Diode	1SS53
D5	Diode	1SS53
D6	Diode	1SS53
D7	Zener	RD6.2EB2
D8	Diode	1SS53
D9	Diode	1S953
D10	Diode	1S953
D11	Diode	1S953
D12	Diode	1SS99
D14	Diode	1SS53
D15	Diode	1SS53
D16	Diode	1SS53

MAIN UNIT

REF. NO.	DESCRIPTION	TYPE (PART NO.)
D17	Diode	1SS53
D18	Diode	1SS53
D19	Diode	1SS53
D20	Zener	RD4.7EB2
D21	Diode	1SS53
D22	Diode	1SS53
D23	Zener	RD6.8EB2
D24	Diode	1S953
D25	Diode	1SS133
FI1	Crystal	30M15B
FI2	Ceramic	CFW455E
X1	Discriminator	CDB455C7A
X2	Crystal	CR125
L1	Coil	LB-50
L2	Coil	LB-34A
L3	Coil	LB-32A (#03, #04, #05)
L4	Coil	LB-1-1A (#03, #04, #05)
L5	Coil	LB-83 (#03, #04, #05)
L6	Coil	LS-145
L8	Coil	LS-199
L9	Coil	LS-189
L10	Coil	LAL03NA-101K
L11	Coil	LA-159
L12	Coil	LW-25
L13	Coil	7HW-252MX-1550-A
L14	Coil	LW-25
L15	Coil	7HW-252MX-1550-A
L16	Coil	LA-147
L18	Coil	LAL02NA-R22
L20	Coil	LS-121A
L22	Coil	LW-15
R1	Resistor	680 ELR20
R2	Resistor	82 ELR20 (#03, #04, #05)
R3	Resistor	6.8k ELR20
R4	Resistor	100 R20
R5	Resistor	180 ELR20
R8	Resistor	100 ELR20
R9	Resistor	100 ELR20
R10	Resistor	4.7k R20
R11	Resistor	22k ELR20
R12	Resistor	330 ELR20
R13	Resistor	100 R20
R14	Resistor	33k ELR20
R15	Resistor	100k ELR20
R16	Resistor	82 ELR20
R17	Resistor	100 ELR20
R18	Resistor	47 ELR20
R19	Resistor	22 ELR20
R20	Resistor	10k ELR20
R21	Resistor	220 ELR20
R24	Resistor	100 ELR20
R25	Resistor	330 ELR20
R26	Thermistor	33D28
R27	Resistor	1.5k ELR20
R28	Resistor	47k ELR20

MAIN UNIT

REF. NO.	DESCRIPTION	TYPE (PART NO.)
R29	Resistor	1.5k ELR20
R30	Resistor	1.5k ELR20
R31	Resistor	4.7k R20
R33	Resistor	1k R20
R34	Resistor	1k ELR20
R35	Resistor	47k ELR20
R36	Resistor	47k ELR20
R37	Resistor	22k ELR20
R38	Resistor	18k ELR20
R39	Resistor	47 ELR20
R40	Resistor	470k ELR20
R41	Resistor	560k ELR20
R42	Trimmer	3.3k H0521A (#03, #04, #05)
R44	Trimmer	47k H0651A
R45	Resistor	10k ELR20
R46	Resistor	2.2k ELR20
R48	Resistor	10k ELR20
R49	Trimmer	2.2k H0651A
R50	Resistor	2.2k R20
R51	Resistor	330k ELR20
R52	Resistor	5.6k ELR20
R53	Resistor	22k R20
R54	Resistor	10k R20
R56	Resistor	15k R20
R57	Resistor	150k ELR20
R58	Resistor	39k R20
R59	Resistor	4.7k ELR20
R60	Resistor	1k R20
R61	Resistor	4.7k ELR20
R62	Resistor	5.6k ELR20
R63	Resistor	47 R20
R64	Resistor	15k ELR20
R66	Resistor	5.6k R20
R67	Resistor	100 ELR20
R68	Resistor	1k R20
R69	Resistor	1k ELR20
R70	Resistor	47k ELR20
R71	Resistor	47k ELR20
R72	Resistor	22k ELR20
R73	Resistor	20k ELR20 (#03, #04, #05)
R74	Resistor	820k ELR20
R75	Resistor	560k ELR20
R76	Trimmer	3.3k H0521A (#03, #04, #05)
R78	Trimmer	47k H0651A
R79	Resistor	22k R20
R81	Resistor	4.7k R20
R82	Trimmer	22k H0651A
R85	Resistor	100 ELR20
R86	Resistor	15k ELR20
R87	Resistor	47 ELR20
R88	Trimmer	2.2k RHBOCJ30EA
R89	Resistor	0.75-J SRW1P
R90	Resistor	4.7k R20
R91	Resistor	4.7k ELR20
R92	Resistor	220 ELR20
R93	Resistor	8.2 ELR20
R96	Resistor	470k ELR20
R97	Resistor	4.7k ELR20
R98	Resistor	4.7k R20
R99	Resistor	10k ELR20
R100	Resistor	10k ELR20
R101	Resistor	100 R20
R102	Resistor	1k ELR20
R103	Resistor	10k R20
R104	Resistor	100 R20

MAIN UNIT

REF. NO.	DESCRIPTION	TYPE (PART NO.)
R105	Trimmer	1k H0521A
R106	Resistor	100 R50
R107	Resistor	1.5k R20
R108	Resistor	1k ELR20
R109	Resistor	820 ELR20
R110	Resistor	1k ELR20
C1	Ceramic	18P 50V
C2	Ceramic	0.001 50V
C3	Ceramic	0.001 50V
C4	Ceramic	30P 50V (#03, #04, #05)
C6	Ceramic	0.001 50V
C7	Ceramic	10P 50V
C8	Ceramic	0.001 50V
C9	Ceramic	0.001 50V
C10	Ceramic	0.001 50V
C11	Ceramic	0.001 50V
C12	Ceramic	36P 50V
C13	Ceramic	1P 50V
C14	Ceramic	12P 50V
C15	Ceramic	120P 50V
C16	Ceramic	68P 50V
C17	Ceramic	0.0047 50V
C18	Ceramic	0.0047 50V
C19	Ceramic	0.001 50V
C20	Ceramic	12P 50V
C21	Trimmer	ECRGA006A30
C22	Ceramic	3P 50V
C23	Ceramic	0.001 50V
C24	Ceramic	0.001 50V
C25	Ceramic	0.001 50V
C26	Ceramic	0.001 50V
C27	Ceramic	0.001 50V
C28	Ceramic	3P 50V
C29	Ceramic	22P 50V
C30	Ceramic	22P 50V
C31	Ceramic	0.001 50V
C32	Ceramic	0.001 50V
C33	Ceramic	22P 50V
C34	Ceramic	3P 50V
C35	Ceramic	47P 50V
C36	Trimmer	ECRGA006A30
C37	Ceramic	12P 50V
C38	Ceramic	0.001 50V
C39	Ceramic	0.001 50V
C40	Electrolytic	47 16V
C41	Ceramic	0.0047 50V
C42	Ceramic	82P 50V
C43	Tantalum	0.1 35V
C44	Barrier Lay	0.1 16V
C45	Ceramic	10P 50V
C46	Ceramic	0.01 50V B
C47	Ceramic	47P 50V
C48	Ceramic	150P 50V
C49	Ceramic	36P 50V
C51	Ceramic	0.001 50V
C52	Ceramic	0.001 50V
C53	Ceramic	0.001 50V
C54	Ceramic	0.001 50V
C55	Ceramic	470P 50V
C56	Ceramic	470P 50V
C57	Ceramic	0.001 50V
C58	Ceramic	0.001 50V
C59	Ceramic	0.001 50V
C60	Ceramic	0.001 50V
C61	Tantalum	1 35V

MAIN UNIT

REF. NO.	DESCRIPTION	TYPE (PART NO.)
C62	Ceramic	0.001 50V
C63	Barrier Lay	0.1 16V
C64	Barrier Lay	0.1 16V
C65	Barrier Lay	0.1 16V
C66	Ceramic	10P 50V
C67	Barrier Lay	0.1 16V
C68	Ceramic	0.001 50V
C69	Ceramic	0.001 50V
C70	Ceramic	0.001 50V
C71	Ceramic	33P 50V
C72	Barrier Lay	TBD05X103M 25V
C73	Electrolytic	2.2 50V MS7
C74	Electrolytic	10 16V MS7
C75	Ceramic	0.0047 50V
C76	Barrier Lay	0.033 25V
C77	Electrolytic	4.7 25V MS7
C78	Electrolytic	47 16V MS7
C79	Barrier Lay	TBD05X103M 25V
C80	Tantalum	0.022 50 F2Z
C81	Barrier Lay	TBD05X103M 25V
C82	Ceramic	0.001 50V
C83	Ceramic	0.001 50V
C84	Ceramic	0.001 50V
C85	Ceramic	0.001 50V
C86	Ceramic	470P 50V
C87	Ceramic	470P 50V
C88	Ceramic	0.001 50V
C89	Ceramic	0.001 50V
C90	Ceramic	0.001 50V
C91	Electrolytic	1000 16V MS16
C92	Electrolytic	1000 16V MS16
C93	Tantalum	1 35V
C94	Tantalum	10 16V
C95	Electrolytic	47 16V MS7
C96	Ceramic	0.001 50V
C98	Barrier Lay	TBD05X103M 25V
C99	Electrolytic	220 10V
C100	Electrolytic	100 10V
C101	Ceramic	0.001 50V
C102	Ceramic	0.001 50V
C103	Ceramic	0.001 50V
C104	Ceramic	0.001 50V
C105	Ceramic	0.001 50V
C106	Ceramic	0.001 50V
C107	Ceramic	0.001 50V
C108	Ceramic	0.001 50V
C109	Ceramic	0.001 50V
C110	Ceramic	0.001 50V
C111	Ceramic	0.001 50V
C112	Ceramic	0.001 50V
C113	Ceramic	0.001 50V
C114	Ceramic	0.001 50V
C115	Ceramic	0.001 50V
C116	Ceramic	0.001 50V
C117	Ceramic	0.0047 50V
C118	Tantalum	1 35V
C119	Barrier Lay	0.1 16V
C120	Ceramic	150P 50V
C121	Ceramic	0.001 50V
J1	Mini pin	TMP-J01X-A2
J2	Mini pin	TMP-J01X-A2
J3	Mini pin	TMP-J01X-A2
J4	Mini pin	TMP-J01X-A2
J5	Connector	B06B-EH-S

MAIN UNIT

REF. NO.	DESCRIPTION	TYPE (PART NO.)
J6	Connector	B06B-EH-S
J7	Connector	B03B-EH-S
J8	Connector	B05B-EH-S
J9	Connector	B03B-EH-S
J10	Connector	B03B-EH-S
J11	Connector	B03B-EH-S
J12	Connector	B05B-EH-S
J13	Connector	B02B-EH-S
J14	Connector	B02B-EH-S
J15	Connector	IMS-A-9201B-1-02-T
J16	Connector	B03B-EH-S
P1	Connector	EHR-08
EP1	MAIN P.C.B	B-943G
EP2	Bead Core	BT01RNI-A61
*EP5	Insulator	40639 (10mm x 10mm)
*EP6	Insulator	41629 (29mm x 25mm)
W18	Jumper	IPS-1041-2
W19	Jumper	IPS-1041-2
W20	Jumper	IPS-1041-2
W21	Jumper	IPS-1041-2
W22	Jumper	IPS-1041-4
W23	Jumper	IPS-1041-2
W24	Jumper	IPS-1041-4
W25	Jumper	IPS-1041-2
W27	Jumper	IPS-1041-4
W28	Jumper	IPS-1041-2
W29	Jumper	IPS-1041-4
W30	Jumper	IPS-1041-2
W31	Jumper	IPS-1041-2
W32	Jumper	IPS-1041-2
W33	Jumper	IPS-1041-2
W34	Jumper	IPS-1041-2
W35	Jumper	IPS-1041-2
W36	Jumper	IPS-1041-4
W37	Jumper	IPS-1041-4
W38	Jumper	IPS-1041-4
W39	Jumper	IPS-1041-4
W40	Jumper	IPS-1041-4

*Located under the MAIN BOARD.

RX VCO UNIT

REF. NO.	DESCRIPTION	TYPE (PART NO.)
Q1	FET	2SK125
Q2	Transistor	2SC3399
Q3	Transistor	2SC3399
Q4	FET	2SK125
Q5	Transistor	2SC2026
D1	Varicap	1T25
D2	Varicap	1T25
L1	Coil	LAL03NA-4R7
L2	Coil	LAL03NA-R39
L3	Coil	LA-188
L4	Coil	LAL03NA-4R7
L5	Coil	LAL03NA-R39
L6	Coil	LAL03NA-4R7
L7	Coil	LAL03NA-R39
L8	Coil	LB-166

RX VCO UNIT

REF. NO.	DESCRIPTION	TYPE (PART NO.)	
R1	Resistor	47	ELR20
R2	Resistor	330	ELR20
R4	Resistor	330	ELR20
R5	Resistor	270	ELR20
R6	Resistor	100	R20
R7	Resistor	6.8k	ELR20
R8	Resistor	1k	ELR20
R9	Resistor	100	ELR20
C1	Ceramic	33P	50V XL
C2	Ceramic	2P	50V CH
C5	Ceramic	15P	50V
C6	Ceramic	8P	50V
C11	Ceramic	0.35P	50V
C12	Ceramic	47P	50V
C13	Ceramic	8P	50V
C14	Ceramic	12P	50V
C15	Ceramic	5P	50V CH
C16	Trimmer	ECR-GA003A30	
C17	Ceramic	12P	50V UJ
C20	Ceramic	470P	50V
C21	Ceramic	0.5P	50V
C22	Ceramic	10P	50V
EP1	RX VCO P.C.B	B-899E	

TX VCO UNIT

REF. NO.	DESCRIPTION	TYPE (PART NO.)	
Q1	FET	2SK125	
Q2	Transistor	2SC2026	
Q3	Transistor	2SC3399	
Q4	Transistor	2SC3399	
Q5	Transistor	2SC945K	
Q6	FET	2SK125	
D1	Varicap	1T25	
D2	Varicap	1T25	
D3	Varicap	1T25	
D4	Varicap	1T25	
D5	Diode	1SS133	
L1	Coil	LAL03NA-R33	
L2	Coil	LA-188	
L4	Coil	LW-19	
L5	Coil	LA-233	
L6	Coil	LAL03NA-4R7	
L7	Coil	LB-141	
L9	Coil	LAL03NA-R82	
L10	Coil	LAL03NA-4R7	
L11	Coil	LAL03NA-R33	
R1	Resistor	47	ELR20
R2	Trimmer	10k	H0521A
R3	Trimmer	10k	H0521A
R4	Resistor	5.6k	ELR20
R5	Resistor	1k	ELR20
R6	Resistor	47	ELR20
R7	Resistor	270	ELR20
R8	Resistor	100	ELR20
R9	Resistor	4.7k	ELR20

TX VCO UNIT

REF. NO.	DESCRIPTION	TYPE (PART NO.)	
R10	Resistor	330	ELR20
R11	Resistor	150	ELR20
R16	Resistor	33k	R20
R17	Resistor	10k	R20
R18	Resistor	47k	R20
R19	Resistor	47k	ELR20
R20	Resistor	10k	R25
R21	Resistor	47k	R20
R23	Resistor	22k	ELR20
R24	Resistor	22k	R20
C1	Ceramic	8P	50V UJ
C2	Trimmer	ECR-GA003A30	
C3	Ceramic	2P	50V CH
C4	Ceramic	0.75P	50V
C6	Ceramic	8P	50V
C7	Ceramic	1P	50V
C8	Ceramic	47P	50V
C9	Ceramic	0.001	50V
C10	Ceramic	47P	50V
C12	Ceramic	15P	50V
C13	Ceramic	47P	50V
C14	Ceramic	0.001	50V
C15	Ceramic	470P	50V
C16	Electrolytic	100	10V MS7
C17	Ceramic	1P	50V
C18	Ceramic	8P	50V
C19	Ceramic	15P	50V
C20	Ceramic	1P	50V
C22	Ceramic	2P	50V CH
C24	Ceramic	33P	50V XL
C25	Ceramic	8P	50V
C27	Feed Through	TF240-602-332	
C28	Feed Through	TF240-602-332	
C29	Feed Through	TF240-602-332	
C30	Ceramic	47P	50V
C31	Ceramic	47P	50V
C32	Ceramic	470P	50V
C33	Ceramic	47P	50V
C34	Cylinder	UP125SL010M-NA	
C35	Tantalum	0.1	35V (#04, #05)
C35	Tantalum	0.47	35V (#03)
C36	Ceramic	47P	50V
EP1	TX VCO P.C.B	B-900E	
EP2	Pin	RT-01T-1.0B	
W1	Jumper	IPS-1041-2	

PLL-YGR UNIT

REF. NO.	DESCRIPTION	TYPE (PART NO.)
IC1	IC	μPD2834C
IC2	IC	μPB571C
IC3	IC	TC4555BP
IC4	IC	M54519
IC5	IC	NJM4558D
IC6	IC	TA78L006AP
IC7	IC	TC4094BP (#03)
IC8	IC	S7116A (#03, #04)
IC9	IC	μPD4066BC

PLL-YGR UNIT

REF. NO.	DESCRIPTION	TYPE (PART NO.)
Q1	Transistor	2SC2458-Y
Q2	Transistor	2SC2458L-GR
Q3	Transistor	2SC2458L-GR
Q4	Transistor	2SA1048-Y
Q5	Transistor	2SC3399
Q6	Transistor	2SC2026
Q7	Transistor	2SC2026
Q8	Transistor	2SC1571-G
Q9	Transistor	2SB909M-R
Q10	Transistor	2SB909M-R
Q11	Transistor	2SB909M-R
Q12	Transistor	2SB909M-R
Q13	Transistor	2SB909M-R
Q14	Transistor	2SB909M-R
Q15	Transistor	2SC2026
Q16	Transistor	2SC2026
Q17	Transistor	2SC2407 (1) (#03, #04, #05)
Q18	Transistor	2SC2026
Q19	Transistor	2SC2407A
Q21	Transistor	2SC3399
Q22	Transistor	2SA1048-Y
Q23	Transistor	2SA1345
Q24	Transistor	2SC3399
D1	Diode	1SS133
D2	Diode	1SS133
D3	Diode	1SS133
D4	Diode	1SS133
D5	Diode	1SS133
D6	Diode	1SS133
D7	Diode	1SS133
D8	Diode	1SS133
D10	Diode	1SS133
D11	Diode	1SS216
D12	Diode	1SS216
D13	Diode	1SS216
D14	Diode	1SS133
D15	Diode	1SS133
X1	Crystal	CR112 (#03, #05)
X1	Crystal	CR113 (#04)
X2	Crystal	3.579545MHz (#03, #04)
L1	Coil	LW-19
L2	Coil	LW-19
L3	Coil	LA-233
L4	Coil	LA-233
L5	Coil	LA-232
L6	Coil	LA-232
L7	Coil	LA-232
L8	Coil	LA-238
L9	Coil	LA-237
L10	Coil	LA-232
L11	Coil	LA-232
L12	Coil	LA-235
L13	Coil	LA-235
R1	Resistor	5.6k ELR20
R2	Resistor	220k ELR20
R3	Resistor	100 R20
R4	Resistor	10k R20 (#04, #05)
R4	Resistor	8.2k R20 (#03)
R5	Resistor	2.2k ELR20
R6	Resistor	100 R20 (#04, #05)
R6	Resistor	1.5k R20 (# 03)

PLL-YGR UNIT

REF. NO.	DESCRIPTION	TYPE (PART NO.)
R8	Resistor	47 ELR20
R9	Resistor	1.5k R25
R12	Resistor	10k ELR20
R13	Resistor	100 R20
R14	Resistor	1k ELR20
R15	Resistor	4.7k R20
R16	Resistor	4.7k ELR20
R17	Resistor	4.7k R25
R18	Resistor	10k ELR20
R19	Resistor	1k R20
R20	Resistor	100 R20
R21	Resistor	5.6k ELR20
R22	Resistor	100 R20
R23	Resistor	100 R20
R24	Resistor	5.6k ELR20
R25	Resistor	1k ELR20
R26	Resistor	47 ELR20
R27	Resistor	100 ELR20
R28	Resistor	1k R20
R29	Resistor	10k R20
R30	Resistor	1k ELR20
R31	Resistor	10k ELR20
R32	Resistor	1k R20
R33	Resistor	10k R20
R34	Resistor	1k ELR20
R35	Resistor	10k ELR20
R36	Resistor	1k R20
R37	Resistor	10k R20
R38	Resistor	1k ELR20
R39	Resistor	10k R20
R42	Trimmer	100k H0651A (#03, #04)
R43	Trimmer	100k H0651A (#03)
R44	Resistor	47k R20 (#03, #04)
R45	Resistor	82k ELR20
R46	Resistor	82k R20
R47	Resistor	390k ELR20
R48	Resistor	270k ELR20
R49	Resistor	150k R20
R50	Trimmer	100k H0651A
R51	Resistor	1.5k ELR20
R52	Resistor	100 R20
R53	Resistor	220k R20
R54	Resistor	270k ELR20
R55	Resistor	100 ELR20
R56	Resistor	1.8k ELR20
R58	Resistor	680k ELR20
R59	Resistor	220 ELR20
R60	Resistor	1k ELR20
R61	Resistor	68 ELR20
R62	Resistor	47 ELR20
R65	Resistor	1k ELR20
R66	Resistor	100 R20
R67	Resistor	4.7k R20
R68	Resistor	1k ELR20
R69	Resistor	150 ELR20
R70	Resistor	47 R50 (#03, #04, #05)
R71	Resistor	2.2k R20
R72	Resistor	5.6k ELR20
R73	Resistor	1k ELR20
R74	Resistor	100 ELR20
R75	Resistor	100 R20
R76	Resistor	150 ELR20
R77	Resistor	1k ELR20
R78	Resistor	4.7k R20
R79	Resistor	2.2k ELR20

PLL-YGR UNIT

REF. NO.	DESCRIPTION	TYPE (PART NO.)
R80	Resistor	18 ELR20
R81	Resistor	270 ELR20
R82	Resistor	270 ELR20
R83	Resistor	2.2k R20
R84	Resistor	1k R20
R85	Resistor	100 ELR20
R86	Resistor	68 ELR20
R87	Resistor	100 ELR20
R89	Resistor	220k ELR20
R90	Resistor	100 R20
R91	Resistor	100k R20
R92	Resistor	100k ELR20
R93	Resistor	82k ELR20
R94	Resistor	10k R20
R95	Resistor	2.7k ELR20 (#04, #05)
R95	Resistor	1.8k ELR20 (#03)
R96	Resistor	22k ELR20 (#04, #05)
R97	Resistor	2.2k R20 (#04, #05)
R97	Resistor	22k R20 (#03)
R98	Resistor	47k ELR20
R99	Resistor	100 R25
R100	Resistor	33k R25 (#03, #04)
R101	Resistor	47 ELR20
R103	Resistor	1k ELR20
R104	Resistor	10k R20
R105	Resistor	6.8k R20
R106	Resistor	39k R20 (#04)
C1	Ceramic	100P 50V
C2	Ceramic	200P 50V
C3	Barrier Lay	TBD05X103M
C4	Ceramic	18P 50V CH
C5	Trimmer	CV05C1201
C6	Cylinder	UP125-B-102K-NA
C7	Electrolytic	470 6.3V MS9
C8	Ceramic	0.001 50V
C9	Ceramic	47P 50V
C10	Ceramic	47P 50V
C11	Ceramic	47P 50V
C12	Ceramic	47P 50V
C13	Cylinder	UP125-SL-101J-NA
C14	Electrolytic	0.47 50V MS7
C15	Electrolytic	10 16V MS7
C16	Ceramic	10P 50V
C17	Barrier Lay	0.1 16V
C18	Electrolytic	470 10V MS9
C20	Ceramic	0.001 50V
C21	Electrolytic	10 16V BP
C24	Ceramic	5P 50V
C25	Ceramic	0.0047 50V
C26	Ceramic	470P 50V
C27	Ceramic	0.001 50V
C28	Ceramic	0.001 50V
C29	Ceramic	0.001 50V
C30	Ceramic	18P 50V
C31	Ceramic	470P 50V
C32	Tantalum	0.1 35V
C34	Ceramic	0.001 50V
C35	Ceramic	470P 50V
C36	Ceramic	470P 50V
C37	Ceramic	47P 50V
C38	Ceramic	0.001 50V
C39	Ceramic	0.001 50V
C40	Ceramic	0.001 50V
C41	Electrolytic	1 50V MS7 (#03, #04)
C42	Ceramic	47P 50V
C43	Ceramic	47P 50V

PLL-YGR UNIT

REF. NO.	DESCRIPTION	TYPE (PART NO.)
C44	Ceramic	47P 50V
C45	Ceramic	47P 50V
C46	Ceramic	47P 50V
C49	Ceramic	33P 50V (#03, #04)
C50	Ceramic	33P 50V (#03, #04)
C51	Ceramic	120P 50V
C52	Mylar	0.0022 50F2Z
C53	Ceramic	0.001 50V
C54	Electrolytic	0.22 50V MS7
C55	Ceramic	0.001 50V
C56	Ceramic	0.001 50V
C57	Barrier Lay	TBD05X103M 25V
C58	Ceramic	0.001 50V
C59	Electrolytic	100 10V MS7
C60	Electrolytic	0.47 50V BP
C61	Ceramic	0.001 50V
C62	Electrolytic	100 10V MS9
C63	Ceramic	3P 50V
C64	Ceramic	0.001 50V
C65	Ceramic	0.001 50V
C66	Ceramic	47P 50V
C67	Ceramic	6P 50V
C69	Ceramic	0.001 50V
C70	Ceramic	0.001 50V
C71	Ceramic	0.001 50V
C72	Ceramic	0.001 50V
C73	Trimmer	CV05E0601 (#03, #04, #05)
C74	Ceramic	1P 50V
C75	Ceramic	470P 50V
C76	Ceramic	470P 50V
C77	Ceramic	0.001 50V
C78	Ceramic	12P 50V (#03, #04, #05)
C79	Ceramic	470P 50V
C80	Ceramic	0.001 50V
C81	Ceramic	10P 50V
C82	Ceramic	0.001 50V
C83	Ceramic	0.001 50V
C84	Ceramic	470P 50V
C85	Ceramic	15P 50V
C86	Ceramic	470P 50V
C87	Ceramic	470P 50V
C88	Ceramic	470P 50V
C89	Ceramic	22P 50V
C90	Ceramic	10P 50V
C91	Ceramic	0.001 50V
C92	Ceramic	470P 50V
C93	Ceramic	39P 50V
C94	Ceramic	8P 50V
C95	Ceramic	6P 50V
C96	Ceramic	8P 50V
C97	Ceramic	10P 50V
C98	Ceramic	47P 50V
C99	Ceramic	15P 50V
C100	Ceramic	39P 50V
C101	Ceramic	39P 50V
C102	Ceramic	470P 50V
C103	Ceramic	47P 50V
C104	Ceramic	0.001 50V
C105	Ceramic	470P 50V
C106	Ceramic	15P 50V
C107	Ceramic	2P 50V
C108	Electrolytic	0.47 50V MS7 (#03, #04)
C109	Electrolytic	0.47 50V MS7 (#03)
C110	Electrolytic	1 50V BP
C111	Barrier Lay	TBD05X103M 25V
C113	Barrier Lay	0.047 25V (#04, #05)
C114	Electrolytic	10 16V MS7 (#04, #05)

PLL-YGR UNIT

REF. NO.	DESCRIPTION	TYPE (PART NO.)
C114	Electrolytic	1 50V MS7 (#03)
C115	Barrier Lay	TBD05X103M 25V (#03)
C118	Electrolytic	1000 10V 12.5 x 12.5
C119	Ceramic	0.001 50V
C120	Ceramic	0.001 50V
C121	Ceramic	0.001 50V
C122	Ceramic	0.001 50V
C123	Ceramic	0.001 50V
C124	Ceramic	0.001 50V
C126	Tantalum	0.1 35V
C127	Electrolytic	100 16V
C128	Ceramic	0.001 50V
C129	Ceramic	470P 50V
C130	Ceramic	0.001 50V
C131	Ceramic	0.001 50V
C132	Ceramic	0.001 50V
C133	Ceramic	0.001 50V
C134	Ceramic	47P 50V
C135	Ceramic	47P 50V
C136	Ceramic	47P 50V
C137	Ceramic	47P 50V
C138	Ceramic	47P 50V
C139	Ceramic	47P 50V
C140	Barrier Lay	0.0047 25V
C142	Tantalum	0.1 35V
C143	Barrier Lay	TBD05X103M 25V
C144	Ceramic	12P 50V
C145	Tantalum	2.2 35V
J1	Mini pin	TMP-J01X-A2
J2	Mini pin	TMP-J01X-A2
J3	Connector	B02B-EH-S
J4	Connector	B08B-EH-S
J5	Connector	B06B-EH-S
J6	Connector	B04B-EH-S
J8	Connector	B03B-EH-S (#04)
P1	Connector	TMP-P01X-A1
P2	Connector	TMP-P01X-A1
EP1	PLL-YGR P.C.B	B-898F
EP2	Insulator	J-40639
W9	Jumper	JPW-02A
W10	Jumper	JPW-02A
W11	Jumper	JPW-02A
W12	Jumper	IPS-1041-2
W13	Jumper	IPS-1041-2
W14	Jumper	IPS-1041-2
W15	Jumper	IPS-1041-2
W16	Jumper	IPS-1041-2
W17	Jumper	IPS-1041-2
W18	Jumper	IPS-1041-2
W19	Jumper	IPS-1041-2
W20	Jumper	IPS-1041-2
W21	Jumper	IPS-1041-2
W22	Jumper	IPS-1041-2
W23	Jumper	IPS-1041-2
W24	Jumper	IPS-1041-2
W25	Jumper	IPS-1041-2 (#03, #05)
W26	Jumper	IPS-1041-2 (#03)
W27	Jumper	IPS-1041-2 (#03)
W28	Jumper	IPS-1041-2 (#03)
W29	Jumper	IPS-1041-2
W30	Jumper	IPS-1041-2 (#03, #04)

PLL-YGR UNIT

REF. NO.	DESCRIPTION	TYPE (PART NO.)
W31	Jumper	IPS-1041-2 (#03)
W32	Jumper	IPS-1041-2
W33	Jumper	IPS-1041-2
W34	Jumper	IPS-1041-2
W35	Jumper	IPS-1041-2
W36	Jumper	IPS-1041-2
W37	Jumper	IPS-1041-2
W38	Jumper	IPS-1041-2
W40	Jumper	IPS-1041-2
W41	Jumper	IPS-1041-4
W42	Jumper	IPS-1041-4
W43	Jumper	IPS-1041-4
W44	Jumper	IPS-1041-4
W45	Jumper	JPW-02A
W46	Jumper	IPS-1041-4
W48	Jumper	IPS-1041-4
W49	Jumper	IPS-1041-4 (#03)
W51	Jumper	IPS-1041-4 (#03)
W52	Jumper	IPS-1041-4
W53	Jumper	IPS-1041-4
W54	Jumper	IPS-1041-4
W55	Jumper	IPS-1041-4
W56	Jumper	IPS-1041-4
W57	Jumper	IPS-1041-4
W58	Jumper	IPS-1041-4
W59	Jumper	IPS-1041-4
W61	Jumper	IPS-1041-4 (#03, #04)
W62	Jumper	IPS-1041-4
W63	Jumper	IPS-1041-4 (#03)
W64	Jumper	IPS-1041-4
W65	Jumper	IPS-1041-4
W66	Jumper	IPS-1041-4
W67	Jumper	IPS-1041-4
W68	Jumper	IPS-1041-4
W69	Jumper	IPS-1041-4
W70	Jumper	IPS-1041-4
W71	Jumper	IPS-1041-4
W75	Jumper	JPW-02A (#04)
W78	Jumper	JPW-02A (#04)
W79	Jumper	IPS-1041-2 (#04)
W80	Jumper	IPS-1041-2 (#04)
W81	Jumper	IPS-1041-2 (#04)
W82	Jumper	IPS-1041-2 (#04)
W83	Jumper	IPS-1041-2 (#04)

LOGIC A UNIT

REF. NO.	DESCRIPTION	TYPE (PART NO.)
IC1	IC	μPD7514G-046-12
IC2	IC	μPD4081BG
IC3	IC	μPD4081BG
IC4	IC	μPD4050BG
IC5	IC	LA6393M
Q1	Transistor	2SC3395
Q2	Transistor	2SC3395
Q3	Transistor	2SC3395
Q4	Transistor	2SC2712-Y
Q5	Transistor	2SC3395
Q6	Transistor	2SC3395
Q7	Transistor	2SC3395
Q8	Transistor	2SC3395
D1	Diode	1SS184

LOGIC A UNIT

REF. NO.	DESCRIPTION	TYPE (PART NO.)	
D2	Diode	1SS193	
D3	Diode	1SS193	
D5	Diode	1SS184	
D6	Diode	1SS187	
D7	Diode	1SS193	
D8	Diode	1SS181	
D9	Diode	1SS193	
D10	Diode	1SS193	
D11	LED	SLP451B	
D12	LED	LN233RP	
D13	LED	LN333GP	
D14	Zener	RD5.6MB2	
R1	Resistor	82k	MCR10
R2	Resistor	82k	MCR10
R3	Resistor	47k	MCR10
R4	Resistor	47k	MCR10
R5	Resistor	100k	MCR10
R6	Resistor	220k	MCR10
R9	Resistor	12k	MCR10
R10	Resistor	47k	MCR10
R11	Resistor	820	MCR10
R13	Resistor	470	MCR10
R14	Resistor	470	MCR10
R15	Resistor	470	MCR10
R16	Resistor	47k	MCR10
R17	Resistor	12k	MCR10
R18	Resistor	1k	MCR10
R19	Resistor	56k	MCR10
R20	Resistor	22k	MCR10
R21	Resistor	100k	MCR10
R22	Resistor	47k	MCR10
R23	Resistor	47k	MCR10
R24	Resistor	10k	MCR10
R25	Resistor	1M	MCR10
R26	Resistor	12k	MCR10
R27	Resistor	12k	MCR10
R28	Resistor	220k	MCR10
R29	Resistor	47k	MCR10
R30	Resistor	47k	MCR10
R31	Resistor	4.7k	MCR10
R32	Resistor	47k	MCR10
R33	Resistor	22k	R20
R34	Resistor	47K	R20
C1	Monolithic	0.001	50V GR40
C2	Monolithic	33P	50V GR40
C3	Monolithic	0.001	50V GR40
C4	Monolithic	0.001	50V GR40
C5	Monolithic	0.001	50V GR40
C6	Monolithic	0.001	50V GR40
C8	Monolithic	0.1	25V GR40
C11	Monolithic	0.001	50V GR40
C13	Monolithic	0.001	50V GR40
C14	Monolithic	0.001	50V GR40
C16	Monolithic	0.001	50V GR40
C17	Monolithic	0.001	50V GR40
C18	Monolithic	0.1	25V GR40
C19	Monolithic	0.01	25V GR40
C20	Monolithic	0.01	25V GR40
C21	Monolithic	33P	50V GR40
J1	Connector	8S-S-E	

LOGIC A UNIT

REF. NO.	DESCRIPTION	TYPE (PART NO.)
P1	Connector	EHR02
P2	Connector	EHR03
P3	Connector	EHR03 (#04)
P4	Connector	EHR03
DS1	Lamp	HRS-7219A-G40
DS2	Lamp	HRS-7219A-G40
DS3	Lamp	HRS-7219A-G40
DS4	LCD	HLC9235-01-300
EP3	LOGIC A P.C.B	B-946E
EP4	LOGIC A P.C.B	B-950C
W8	Jumper	MCR10-JPW (#04, #05)
W11	Jumper	MCR10-JPW (#03, #05)
W12	Jumper	MCR10-JPW (#04)

LOGIC B UNIT

REF. NO.	DESCRIPTION	TYPE (PART NO.)
IC1	IC	μPD4028BC
IC2	IC	μPD4013BC
IC3	IC	μPD4030BC
Q1	Transistor	2SC2458-GR
Q2	Transistor	2SA1345
D1	LED	TLR123
D2	Diode	1SS133
D3	Diode	1SS133
D5	Diode	1SS133
D6	Diode	1SS133
D7	Diode	1SS133
D8	Diode	1SS133
D9	Diode	1SS133
D10	Diode	1SS133
D12	Diode	1SS133
D13	Diode	1SS133
D14	Diode	1SS211
D15	Diode	1SS953 (#04)
D16	Diode	1SS133 (#03, #05)
D17	Diode	1SS133 (#03)
D18	Diode	1SS133 (#03)
D19	Diode	1SS133 (#04)
D20	Diode	1SS133 (#04)
D21	Diode	1SS133 (#04)
D22	Diode	1SS133 (#05)
D23	Diode	1SS133
D24	Diode	1SS133 (#03, #04, #05)
D25	Diode	1SS133 (#03, #05)
D26	Diode	1SS133
D27	Diode	1SS133 (#04)
D28	Diode	1SS133
D29	Diode	1SS133 (#03, #05)
D30	Diode	1SS133 (#04)
D31	Diode	1SS133 (#03, #05)
D32	Diode	1SS133
D33	Diode	1SS133
R1	Resistor	5.6k R20
R2	Resistor	22k ELR20

LOGIC B UNIT

REF. NO.	DESCRIPTION	TYPE (PART NO.)	
R3	Resistor	220k	ELR20
R4	Resistor	4.7k	R20
R5	Resistor	39k	ELR20
R6	Resistor	220k	ELR20
R7	Resistor	1M	ELR20
R8	Resistor	47k	ELR20
R9	Resistor	68k	R20
R10	Resistor	120k	ELR20
R11	Resistor	68k	ELR20
R12	Resistor	47k	RM4
R13	Resistor	47k	RM4
C1	Ceramic	47P	50V
C2	Ceramic	47P	50V
C3	Electrolytic	10	16V MS7
C4	Electrolytic	10	16V MS7
C5	Electrolytic	10	16V MS7
C6	Barrier Lay	TBD05X103M	25V
C7	Barrier Lay	0.0027	25V
C8	Barrier Lay	TBD05X103M	25V
C9	Ceramic	100P	50V
C10	Ceramic	470P	50V
C11	Barrier Lay	0.0027	25V
C12	Barrier Lay	TBD05X103M	25V
C13	Barrier Lay	TBD05X103M	25V
C14	Barrier Lay	TBD05X103M	25V
C15	Electrolytic	470	6.3V MS9
J1	Connector	FH3-16S-12.5DSA	
J2	Connector	FH3-16S-12.5DSA	
J3	Connector	B04B-EH-S	
J4	Connector	TLB-P03H-B1	
J5	Connector	TLB-P02H-B1	
J6	Connector	TLB-P05H-B1	
J7	Connector	TLB-P07H-B1	
J8	Connector	TLB-P02H-B1	
J9	Connector	TLB-P03H-B1	
J10	Connector	IMSA-9201B-1-02-T	
P1	Connector	EHR-06	
P2	Connector	EHR-04	
P3	Connector	EHR-05	
P4	Connector	IMSA-9201-HT	
P7	Connector	EHR-05	
S1	Switch	SGK1042	
S2	Rotary Encoder	LA21613	
BT1	Lithium battery	BR2325-1HC	
EP1	LOGIC B P.C.B	B-947E	

PA (UHF AND VHF) UNITS

REF. NO.	DESCRIPTION	TYPE (PART NO.)	
IC1	IC	SC1019	
IC2	IC	SC1027	

PA (UHF AND VHF) UNITS

REF. NO.	DESCRIPTION	TYPE (PART NO.)	
Q1	Transistor	2SA1359-Y	
Q2	Transistor	2SA1345	
Q3	Transistor	2SA1359-Y	
Q4	Transistor	2SA1345	
D1	Diode	15CD11	
D2	Diode	MI407	
D3	Diode	1SS99	
D4	Diode	MI407	
D5	Diode	MI407	
D6	Diode	1SS99	
D7	Diode	MI407	
L1	Coil	LW-25	
L2	Coil	LA-244	
L3	Coil	LA-235	
L4	Coil	LA-263	
L5	Coil	LW-19	
L6	Coil	LA-235	
L7	Coil	LA-238	
L8	Coil	LA-136	
L9	Coil	LA-120	
L10	Coil	LA-242	
L11	Coil	LA-232	
L12	Coil	LA-232	
L13	Coil	LA-232	
L14	Coil	LA-232	
L15	Coil	LA-242	
R1	Resistor	0.15	RGB2
R2	Resistor	100	R50
R3	Resistor	470	ELR20
R4	Resistor	100k	R20
R5	Resistor	10k	ELR20
R6	Resistor	0.15	RGB2
R7	Resistor	100	R50
R8	Resistor	470	ELR20
R9	Resistor	100k	R20
R10	Resistor	10k	R20
R11	Resistor	0.15	RGB2
R12	Resistor	150	R25
C1	Ceramic	0.001	50V
C2	Ceramic	0.001	50V
C3	Ceramic	0.001	50V
C4	Ceramic	0.001	50V
C5	Electrolytic	10	16V MS7
C6	Ceramic	0.001	50V
C7	Tantalum	DNIV	100MIS
C8	Ceramic	0.001	50V
C9	Ceramic	0.5P	50V
C10	Ceramic	22P	500V
C11	Ceramic	0.001	500V
C12	Ceramic	18P	500V
C13	Ceramic	39P	500V
C14	Ceramic	39P	500V
C15	Ceramic	15P	500V
C16	Ceramic	0.001	50V
C17	Ceramic	20P	50V

PA (UHF AND VHF) UNITS

REF. NO.	DESCRIPTION	TYPE (PART NO.)
C18	Ceramic	100P 500V
C19	Ceramic	0.001 50V
C20	Ceramic	0.001 50V
C21	Ceramic	0.001 50V
C22	Ceramic	0.001 50V
C23	Electrolytic	10 16V MS7
C24	Ceramic	47P 50V
C25	Ceramic	2P 500V
C26	Ceramic	2P 500V
C27	Ceramic	0.5P 50V
C28	Ceramic	0.001 50V
C29	Electrolytic	220 16V (SS) 8 x 12
C30	Ceramic	2P 500V
C31	Ceramic	39P 500V
C32	Ceramic	6P 500V
C33	Ceramic	10P 500V
C34	Ceramic	6P 500V
C35	Ceramic	6P 500V
C36	Ceramic	4P 500V
C37	Ceramic	6P 500V
C38	Ceramic	4P 500V
C39	Ceramic	5P 50V
C40	Ceramic	20P 50V
C41	Ceramic	20P 50V
C42	Feed Through	TF240-602-332
C43	Feed Through	TF240-602-332
C44	Feed Through	TF240-602-332
C45	Feed Through	TF240-602-332
C46	Feed Through	TF240-602-332
C47	Feed Through	TF240-602-332
C48	Ceramic	0.001 50V
C49	Ceramic	0.001 50V
C50	Ceramic	0.001 500V
J1	Connector	SJ-296
P1	Connector	EHR-06
P2	Connector	EHR-02
P3	Connector	EHR-06
P4	Connector	EHR-03
P5	Connector	TMP-P01X-A1
P6	Connector	TMP-P01X-A1
P7	Connector	TMP-P01X-A1
P8	Connector	TMP-P01X-A1
EP1	Pin	RT-01T-1.0B
EP2	DC Code	OPC-084
EP3	ANT.Code	OPC-090
EP4	PA P.C.B	B-944D
EP5	PA P.C.B	B-945C
EP6	Ferrite bead	DL2-OP-2.6-3-1.2H
EP7	Ferrite bead	DL2-OP-2.6-3-1.2H
EP8	Ferrite bead	DL2-OP-2.6-3-1.2H
EP20	Ferrite bead	DL2-OP-2.6-3-1.2H

IC-3200

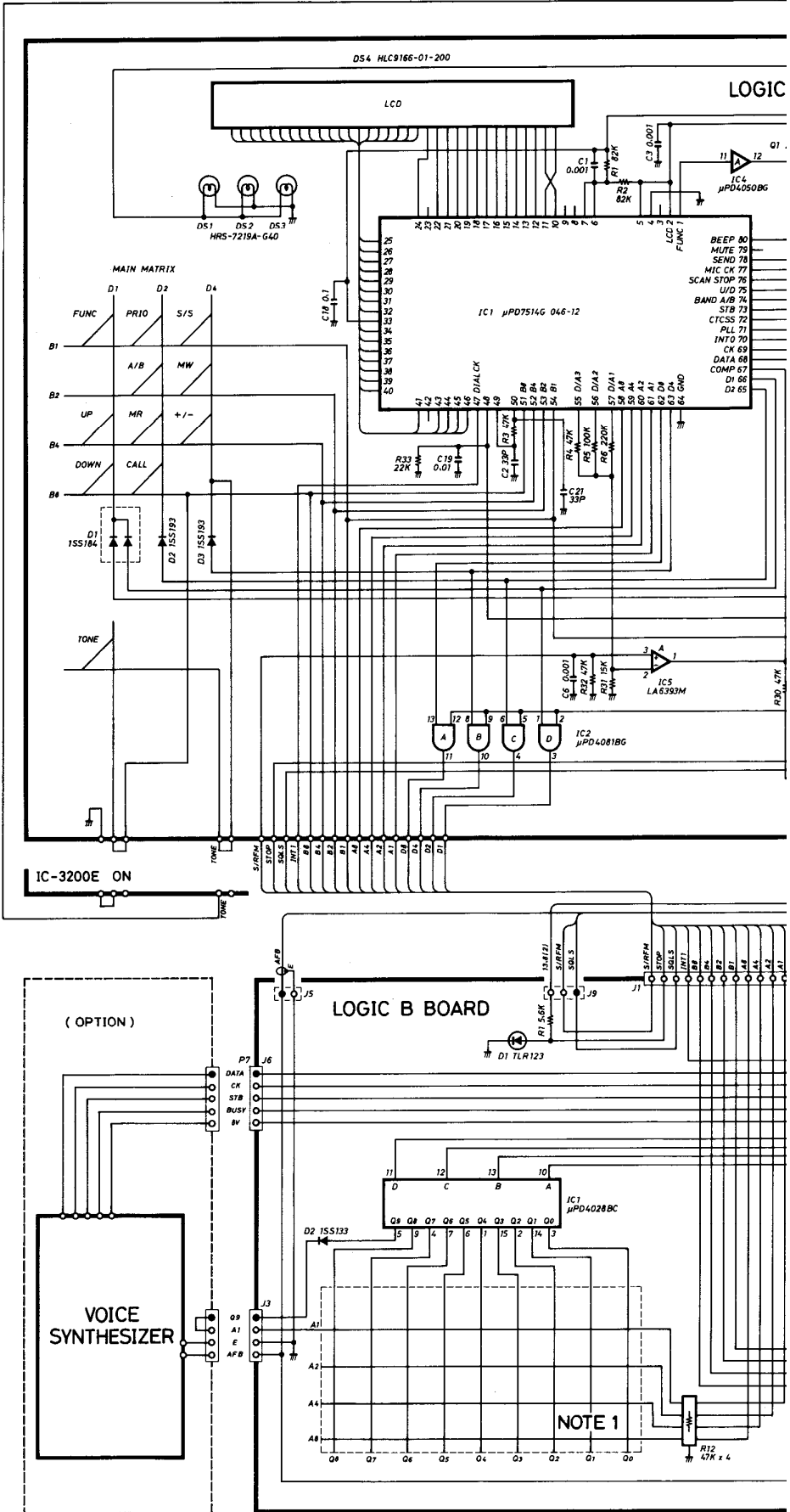
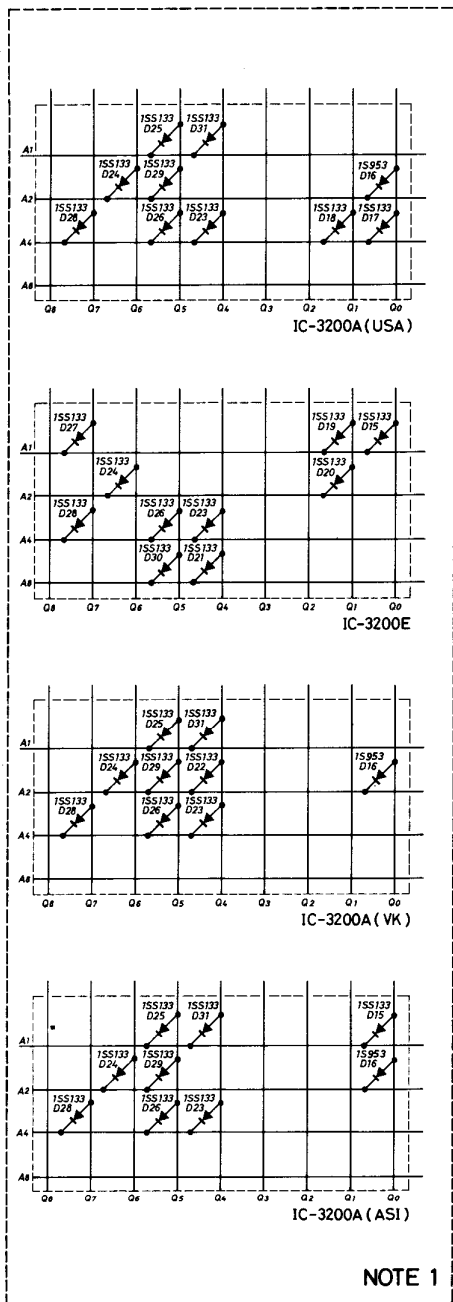

GRAM

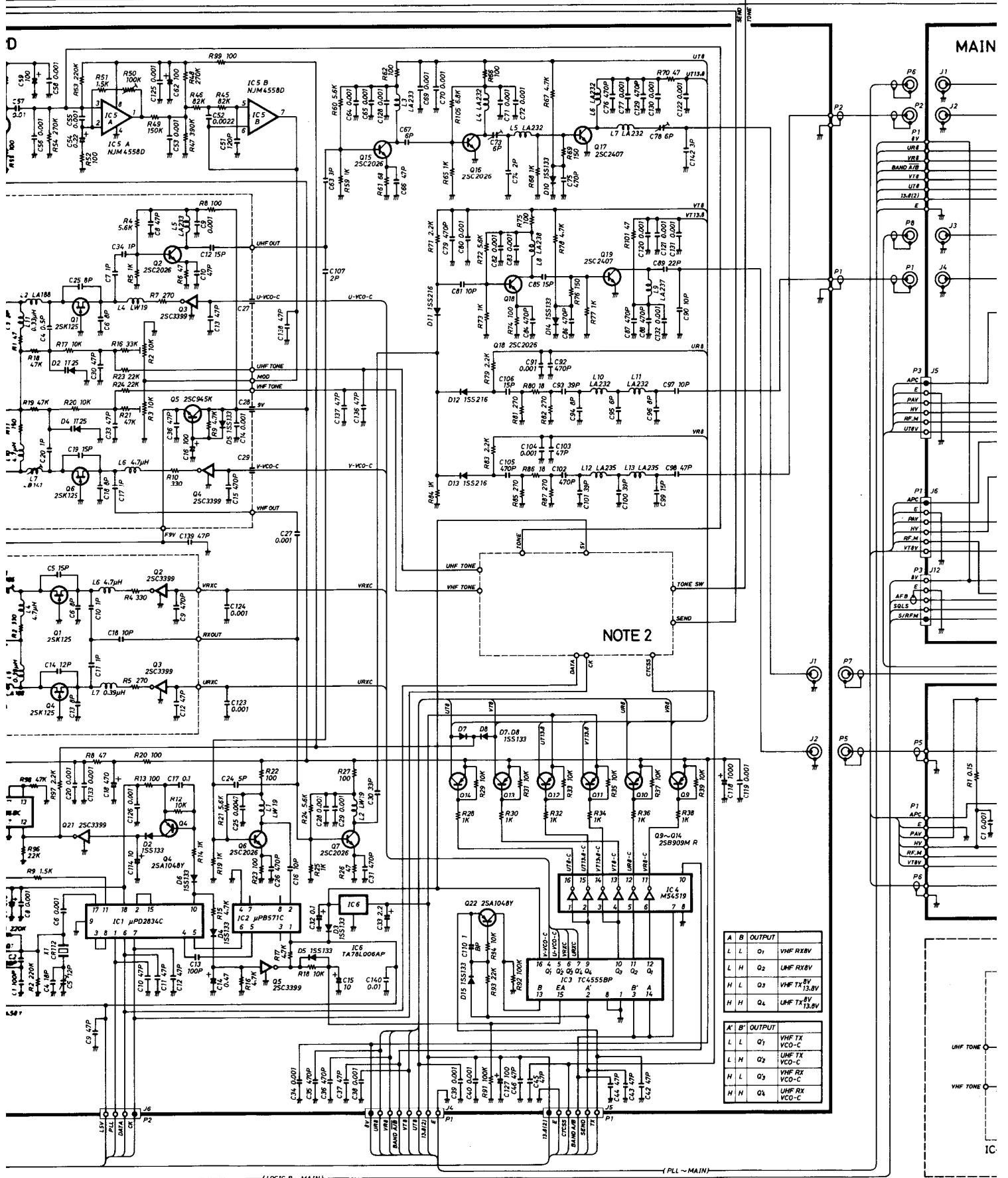

NOTE 2

A	B	OUTPUT
L	L	O ₁ VHF RX BV
L	H	O ₂ UHF RX BV
H	L	O ₃ VHF TX VCO-C
H	H	O ₄ UHF TX 13.8V
H	H	O ₄ UHF TX 13.8V

A'	B'	OUTPUT
L	L	O ₁ VHF TX VCO-C
L	H	O ₂ UHF TX VCO-C
H	L	O ₃ VHF RX VCO-C
H	H	O ₄ UHF RX VCO-C

(LOGIC B ~ MAIN)

(PLL ~ MAIN)

IC

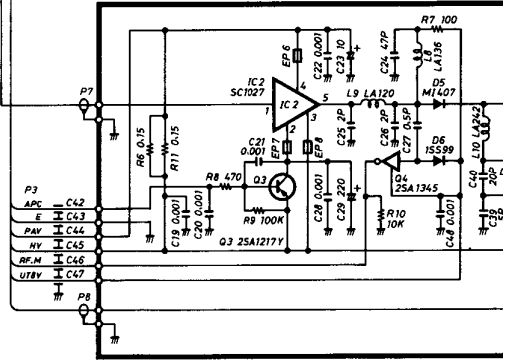
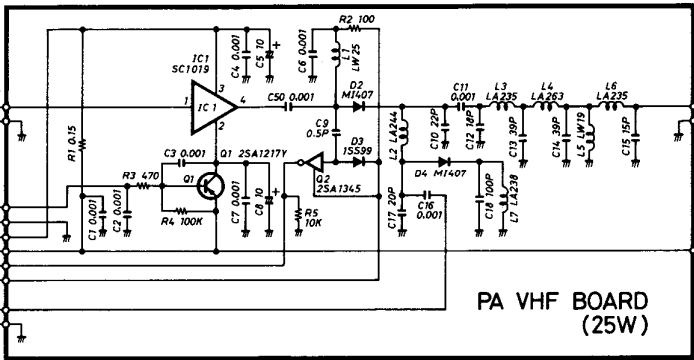
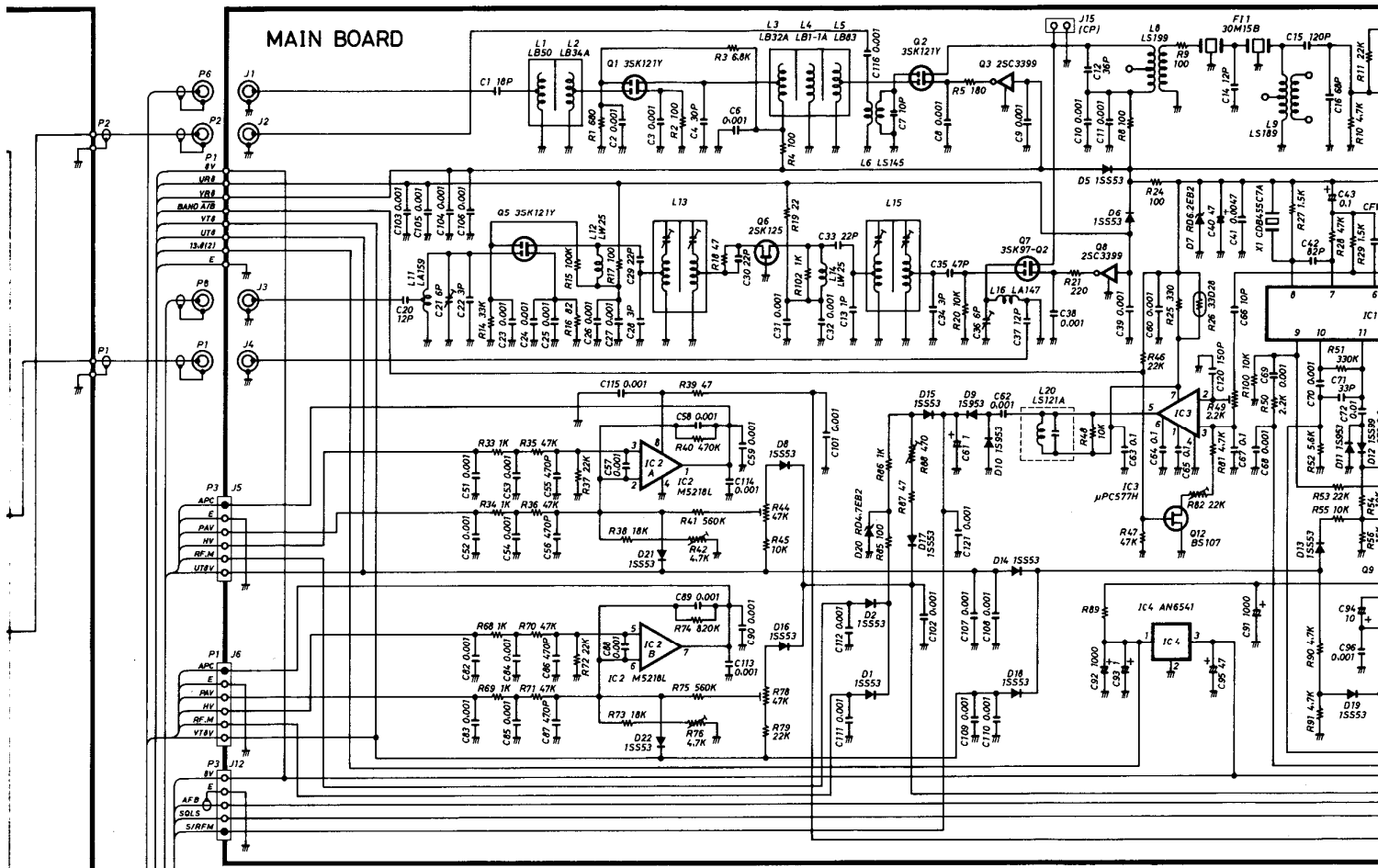

- YHF RXV
- LMF RXV
- YHF TX 8V
- YHF TX 13.5V
- LMF TX 8V
- LMF TX 13.5V
- YHF TX VCO-C
- LMF TX VCO-C
- YHF TX VCO-C
- LMF TX VCO-C
- YHF RX VCO-C
- LMF RX VCO-C

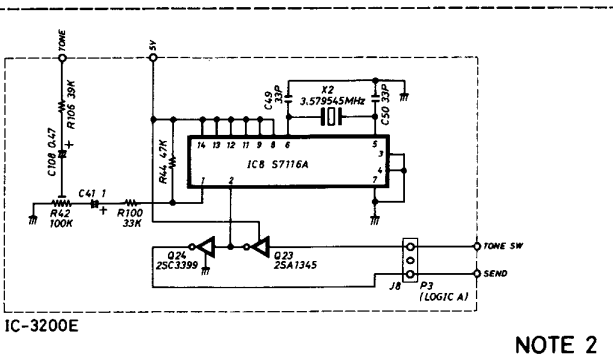
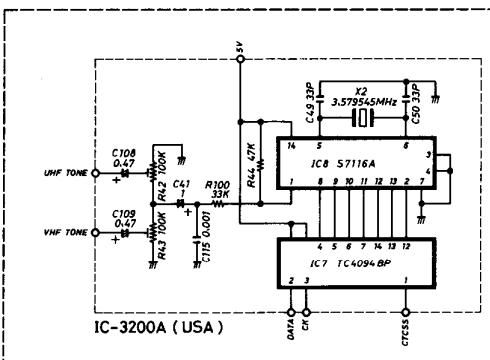

NOTE 2

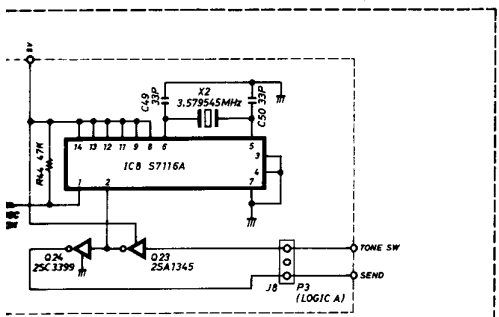
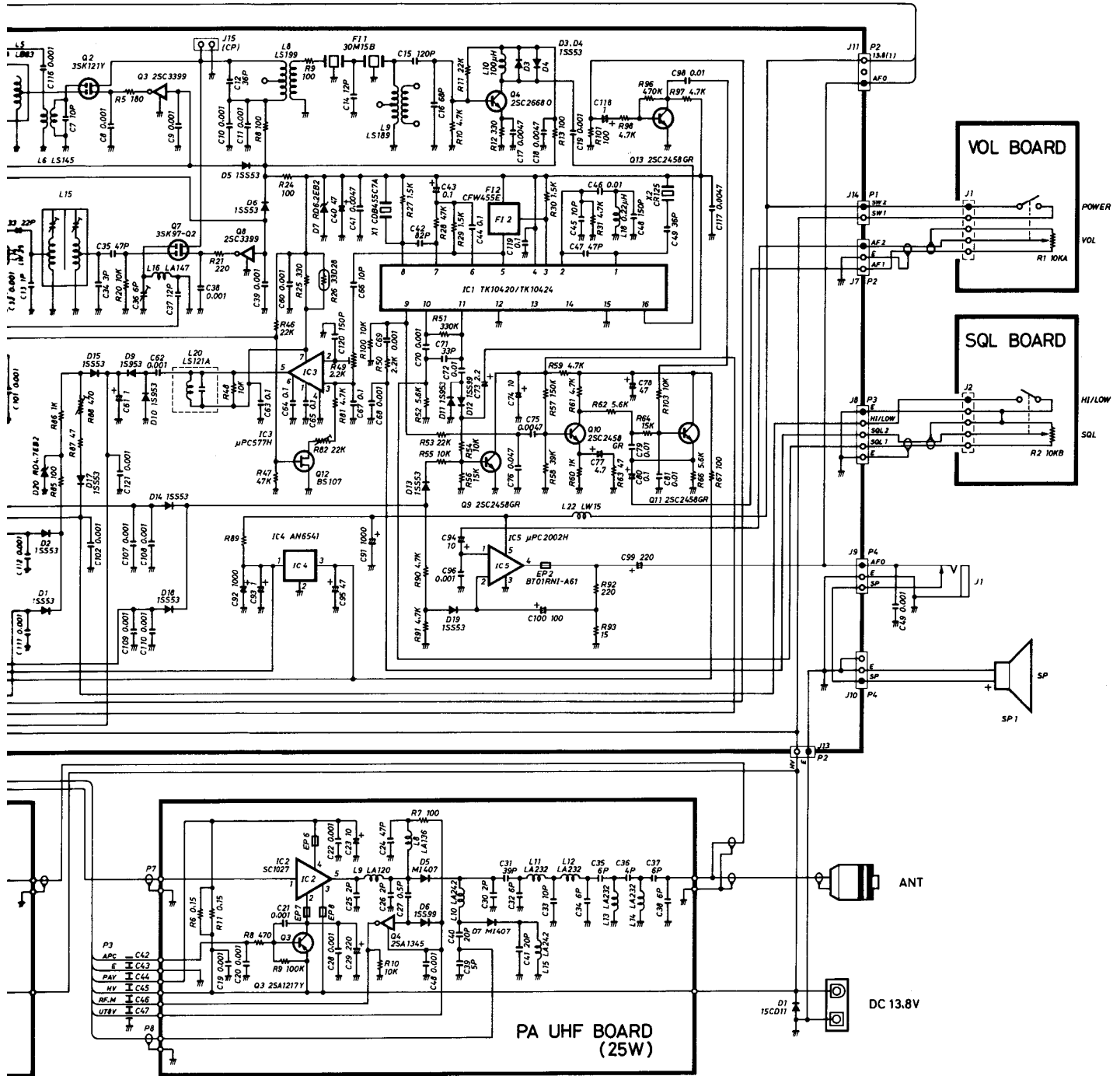

NOTE 2